

FX65



CHAMPIONS START HERE.™

*Owners
Parts
Service
Tuning*

For **parts orders** contact your local dealer

To locate your closest Cobra dealer

log on to

www.cobramotorcycle.com

or call

(517) 437 9100

If you need **technical assistance**

contact your local dealer or call

the Cobra Technical Support Hotline at

+1(517) 437 9100



Cobra MOTO, LLC
240 Uran Road
Hillsdale, MI 49242

DISCLAIMER OF WARRANTY

This motorcycle is sold "as is" with all faults, obvious or not. There are no warranties expressed or implied, including any warranty of merchantability and warranty of fitness for any particular purpose.

Motorcycles are generally not covered by homeowner or trailer content insurance, and they typically require their own policy. Contact your own insurance company for specific details.

"WARNING"

THE COBRA CX65 IS A COMPETITION MODEL ONLY AND IS NOT MANUFACTURED FOR, NOR SHOULD IT BE USED ON PUBLIC STREETS, ROADS OR HIGHWAYS.

THE USE OF THIS BIKE SHOULD BE LIMITED TO PARTICIPATION IN SANCTIONED COMPETITION EVENTS UPON A CLOSED COURSE BY A SUFFICIENTLY SKILLED RIDER AND SHOULD NOT BE USED FOR GENERAL OFF-ROAD RECREATIONAL RIDING.

IMPROPER USE OF THIS MOTORCYCLE CAN CAUSE INJURY OR DEATH.

THIS BIKE IS INTENDED FOR EXPERIENCED RACERS ONLY AND NOT FOR BEGINNERS.

IT IS YOUR RESPONSIBILITY AS THE OWNER OF THIS COBRA MOTORCYCLE OR AS THE PARENT, OR LEGAL GUARDIAN OF THE OPERATOR, TO KEEP THIS COBRA MOTORCYCLE IN PROPER OPERATING CONDITION.

THIS BIKE WAS DESIGNED FOR RIDERS THAT WEIGH LESS THAN 110 LBS WITH FULL RIDING GEAR AND SHOULD NOT BE OPERATED BY RIDERS THAT WEIGH MORE THAN THAT.

BE SURE THAT THE RIDER ALWAYS WEARS ADEQUATE SAFETY GEAR EVERYTIME HE OR SHE RIDES THEIR COBRA MOTORCYCLE.

IMPORTANT SAFETY NOTICE

WARNING

Failure to follow WARNING instructions could result in severe injury or death to the machine operator, a bystander, or a person inspecting or repairing the machine.

CAUTION:

A CAUTION indicates special precautions that must be taken to avoid damage to the machine.

NOTE:

A NOTE provides key information to make procedures easier or clearer.

Table of Contents

GENERAL INFORMATION	6
SPECIFICATIONS - GENERAL.....	6
OPTIONAL COMPONENTS	7
SPECIFICATIONS - TORQUE VALUES.....	8
BREAK-IN PROCEDURE	9
STARTING PROCEDURE	10
MAINTENANCE	11
TIPS	11
SCHEDULE	11
REPLACING TRANSMISSION / CLUTCH LUBRICANT	12
CHAIN ADJUSTMENT	13
LEVER ADJUSTMENT.....	14
REAR BRAKE PEDAL HEIGHT.....	14
AIR FILTER CLEANING.....	15
FORK MAINTENANCE.....	17
FORK AIR BLEEDING	17
FORK OIL REPLACEMENT	17
IGNITION TIMING	19
PARTS.....	20
PARTS – AIR BOX & INLET SYSTEM.....	20
PARTS – BARS AND CONTROLS	21
PARTS - CARBURETOR	22
PARTS – CLUTCH – MASTER CYLINDER.....	23
PARTS – COOLANT SYSTEM.....	24
PARTS – ELECTRICAL SYSTEM.....	25
PARTS – ENGINE CLUTCH	26
PARTS – ENGINE – CLUTCH / KICK COVER	27
PARTS – ENGINE – IGNITION SIDE.....	28
PARTS – ENGINE – KICK MECHANISM & WATER PUMP.....	29
PARTS – ENGINE – SHIFT MECHANISM	30
PARTS – ENGINE – TOP END	31
PARTS – ENGINE – TRANSMISSION.....	33
PARTS – ENGINE – POWER VALVE.....	35

PARTS – EXHAUST SYSTEM	36
PARTS – FORKS & TRIPLE CLAMPS	37
PARTS – FORK – LEG ASSEMBLY – BRAKE SIDE	39
PARTS – FORK – LEG ASSEMBLY – NON-BRAKE SIDE	40
PARTS – FRAME	41
PARTS – FRONT WHEEL	42
PARTS – FRONT BRAKES – MASTER CYLINDER	43
PARTS – FRONT BRAKES – CALIPER.....	44
PARTS – PLASTIC BODYWORK & SEAT	45
PARTS – REAR BRAKE	47
PARTS – REAR WHEEL	48
PARTS – SHOCK EXTERNAL	49
PARTS – SHOCK – INTERNAL.....	50
PARTS – SWINGARM ASSEMBLY	51
SERVICE	52
ENGINE SERVICE.....	52
<i>Base Gasket Selection</i>	53
POWER VALVE.....	54
FUEL & AIR SYSTEM.....	57
CARBURETOR:	57
REAR SHOCK	58
BRAKES	58
<i>Rear Brakes</i>	59
<i>Front Brakes</i>	60
FRONT WHEEL.....	60
<i>Assembly</i>	60
IGNITION	61
TUNING	62
GEARING.....	62
SUSPENSION.....	63
<i>Adjustment:</i>	63
<i>Fork Damping Adjustments</i>	64
<i>Rear Shock Adjustments</i>	65
CARBURETOR.....	66
TROUBLESHOOTING	68

General Information

Specifications - General

Items	CX65
Dimensions	
Wheelbase	45.4" (1051mm)
Wheel size	12" (305mm) rear, 14" (356mm) front
Seat height	29.9" (760mm)
Fuel tank volume	.7 gallon, 2600 cc
Engine	
Type	2-stroke, single cylinder, reed valve
Cooling system	Liquid-cooled, <i>VP Racing – STAY FROSTY</i>
Displacement	64.9 cc
Bore and stroke	44.5 mm x 41.7 mm
Ignition system	Electronic, digital advance
Spark plug	Autolite 4063 or XS4063
Gap	0.024" – 0.026" (0.60 – 0.65 mm)
Ignition timing	Digital advance (set at "0" timing mark)
Fuel type	High octane pump gasoline or VP Racing C50(pre-mixed)
Premix Oil type	VP Racing X2 1050
Premix oil ratio after break-in	32:1
Carburetion	26 mm VM Mikuni
Main Jet / Slow (Pilot) Jet	280 / 42.5
Needle	5I 14 – 4
Needle clip position	4 th slot from top of needle- stock position
Float Height	21.1 ± 1.0
Transmission	6 speed
Final drive ratio	14/43
Chain	112 links 420
Transmission / clutch oil type	VP Racing SAE 80 Gear Lube
Quantity	530 ml (18.0oz)
Chassis	
Front tire	60/100 – 14
Rear tire	80/100 – 12
Front fork	CARD 37mm USD, Fully adjustable
Fork oil type	SAE 5.0 WT
Fork oil amount	250 ml (8.5oz)
Adjustments (turns out)	Compression 1 1/2, Rebound 5/8, Bottoming 1
Rear shock (clicks out)	Compression Low 12, High 15, Rebound 16 Race sag 87mm, Free sag 29mm

Optional Components

Weight of Rider	Fork Spring	Shock Spring
		35.0 N/mm (200 lb/in) SCC60200P (Green)
Even lighter yet	0.20 kg/mm KCC63720	38.5 N/mm (220 lb/in) SCC60220P (Red)
Even lighter	0.22 kg/mm KCC63722	42.0 N/mm (240 lb/in) SCC60240P
Less than 70 lb	0.24 kg/mm KCC63724	45.5 N/mm (260 lb/in) SCC60260P (yellow)
75 – 85 lb stock	0.26 kg/mm KCC63726	49 N/mm (280 lb/in) SCC60280P (black)
80 – 90 lb	0.28 kg/mm KCC63728	52 N/mm (300 lb/in) SCC60300P (red or gray)
90 – 100 lb	0.30 kg/mm KCC63730	52 N/mm (300 lb/in) SCC60300P (red or gray)

Specifications - Torque Values

Fastener	Torque Value			Note or Loctite™	Size & Remarks
	ft-lb	in-lb	Nm		
Cylinder head nuts	9	110	12		M6 x 1.0
Cylinder nuts	22	265	30		M8 x 1.25**
Crankcase bolts	9	110	12		M6 x 1.0
PV Cap Screws	3	35	4		M5 x 0.8
Exhaust Flange	4.5	53	6		M6 x 1.0
Spark plug	(SP)	(SP)	(SP)		M14 x 1.25
Stator bolts	2.1	25	2.8	243 blue	M5 X 0.8
Stator cover bolts	1.7	20	2.3		M4 X 0.75
Clutch cover bolts	5.8	70	7.9		M6 X 1.0
Clutch bolts (6)	6.0	72	8.2	243 blue	M5 x 0.8
Clutch nut	40	480	54	243 blue	M10 x 1.25
Crank drive nut	33	400	45	243 blue	M10 x 1.25
Front axle bolt	33	400	45		M20 x 1.0
Front axle pinch bolt	8.8	106	12		M6 X 1.0
Fork guard alum bolts	6	88	8	Moly lube	M6X1, ALUM
Front brake rotor	7.4	88.5	10		M6 x 1.0
Engine mount bolts	22	265	30		M8 X 1.25
Swingarm pivot	21	250	28		M12 X 1.5
Intake manifold bolts	4.6	55	6.2		M6 X 1.0
Rear axle	21	250	28		M14 X 1.5
Rear sprocket	21	250	28		M7 X 1.0
Rear brake rotor	7.4	88.5	10	243 blue	M6 x 1.0
Rear brake banjo bolts	11	132	15		M8x1.25
Rear brake pad bolts	3	35	4	Retainer clip	M5 x 0.8
Shock bolt	35	420	47	243 blue	M10 x 1.5
Triple clamp bolt (top)	8	90	10		M8 x 1.25
Steering stem pinch bolt	9.5	115	13		M8 x 1.25
Triple clamp bolts	6	72	8		M6 x 1.0
Lever pivot bolts	2.1	25	2.8	243 blue	M5 x .8
Fork cap	15	177	20		
Fork Damper Nut	11	133	15		
Ignition rotor nut	33	400	45	243 blue	M10 x 1.25
Spoke nipple – front	3.7	44	5		
Spoke nipple - rear	4.5	53	6		

** Use a 'crows foot' attachment oriented 90° to the torque wrench

(SP) To apply the proper torque to the spark plug when inserting, one must first screw the spark plug in until the metal gasket ring causes resistance and then turn another 1/8 to ¼ turn.

Break-In Procedure

Your Cobra CX65 is a close-tolerance high performance machine and break-in time is very important for maximum life and performance. The CX65 can be ridden hard after the first ½ hour break-in time.

Cobra recommends VP Racing X2 1050 premix oil with high octane pump gas mixed at 40:1 or VP Racing C50 race fuel.

CAUTION:

Failure to use proper fuel, oil, or fuel/oil mixture may result in premature engine wear or damage to the machine.

Adhering to the following break-in schedule will result in long lasting high performance machine.

- Start bike on stand
- First 5-minute period, operate the bike on the stand with a combination of idle and high RPM operation. (avoid prolonged high RPM but spin the rear wheel good at least once or twice per minute)
- Allow bike to cool
- Ride for 15 minutes, maximum (avoid prolonged high RPM operation and avoid abusing the clutch).
- Cool and inspect bike for loose fasteners.
- Check & retighten wheel spokes
- Next ½ hour of operation, avoid prolonged operation at Wide Open Throttle.
- After 1 hour of operation
 - Check for loose bolts and nuts on the bike and retighten as necessary (proper torque values are listed under Specifications).
 - Clean the carburetor bowl.
 - Change the transmission / clutch lubricant.
- After 8 hours of operation
 - Change the fork oil.
 - Have a Certified Cobra Mechanic change the shock oil.
- Your bike is now ready for the highest level of competition!

Starting Procedure

Before starting the machine inspect the following:

- Check for proper tire pressure in both tires.
- Observe the chain tension and adjust if necessary.
- Observe the coolant level and fill if necessary.
- Verify that the chain rollers and sliders do not have improper wear.
- Verify that the handlebars are tight.
- Check the throttle for smooth operation and sound closing.
- Check for loose bolts and nuts, and re-torque as necessary.
- Verify that the air filter is clean and properly saturated with oil.
- Insure that the fuel tank contains an adequate volume of fuel / oil mixture to complete the distance required.
- Turn the fuel on by rotating the fuel petcock lever to the vertically downward position.

CAUTION:

For best results from your Cobra Motorcycle use only the recommended fuels. 'Race' fuels can be used, however, they are not required with the stock engine, and the engine will require addition attention to maintain proper jetting as weather condition change throughout the day.

WARNING

Always wear a helmet and other protective riding gear.

When your pre-ride inspection is complete the bike may be started. For a cold engine follow this procedure.

1. Place the motorcycle on a stand of sufficient strength that positions the motorcycle in a level upright position with the rear wheel off the ground.
2. Engage the choke by pulling out on the choke button until it stops.
3. Kick start the engine.
4. Rev the engine in short spurts, turning the throttle no more than 1/4 open until the engine will run without the choke.
5. Verify a functional engine shut-off switch by shutting off the engine.
6. Restart the engine and proceed with riding when the engine is sufficiently warm (i.e. the side of the cylinder is warm to touch).

CAUTION:

Never rev an engine full throttle when it's cold or slightly warmed up. This may lead to premature wear of engine components or complete cold seizure of the engine.

CAUTION:

Cobra recommends that you tell your child to take it easy the first couple of minutes in practice until the engine comes up to full operating temperature.

Maintenance

It is important that you adhere to this maintenance schedule so as to promote the longevity of your Cobra Motorcycle.

Tips

1. Cobra lubricants:
 - a. *VP Racing SAE 80 Gear Lube* is the recommended transmission & clutch case lubricant.
 - b. *VP Racing X2 1050* oil is the recommended **premix oil**:
2. Fill your transmission only with the recommended amount of oil. Overfilling may lead to premature seal failure.
3. The cylinder base gasket has been 'fitted' for your engine. See the service section of this manual for instructions how to properly size a base gasket during an engine rebuild.
4. Evaluate the bikes jetting only after it has been warmed up to race temperatures.
5. A properly maintained machine is safer, faster, and more fun to ride.
6. New chains will stretch on first use. Never install a new chain prior to a race. Always 'break' them in during practice.
7. Your Cobra Motorcycle has a 10-digit VIN (Vehicle Identification Number). The first three digits indicate the model while the sixth and seventh indicates the model year.
 - a. Example, CCXxx17xxx is a 2017 CX65.

Schedule

- Prior to each ride
 - Check the air filter (clean and re-oil as necessary).
 - Insure the smooth operation of the throttle cable (throttle soundly 'clacks' shut).
 - Check for frayed strands of the throttle cable inside the throttle housing and replace if necessary.
 - Check for adequate tire pressures and adjust if necessary.
 - Check all nuts and bolts for proper torque and re-torque if necessary.
 - Check drive chain for
 - Proper tension and adjust if necessary.
 - Adequate lubrication and lubricate if necessary.
 - Insure that the ignition stator and rotor are clean and dry.
 - Check the frame for cracks in the metal or cracks in the paint that might indicate that the metal has been stressed beyond its safe limits. Replace or get properly re-welded as necessary.
 - Check the spokes for tightness and adjust if necessary.
 - Check the rims and hubs for signs of stress, like cracks around the rim, spokes and hub.
 - Equalize the pressure in the forks with atmosphere.
 - Check for adequate brake operation and pad thickness

- Every 2 hours of operation
 - Replace the transmission oil.
 - Check spoke tension
- Every 10 hours of operation
 - Replace the fork oil.
 - Have the shock oil replaced by a Certified Cobra Mechanic
- Every 15 hours
 - Replace piston rings
 - Inspect piston for wear and cracks.
 - Clean the power valve (no adjustment necessary)
 - Inspect the power valve cable.

CAUTION:

If you ever need to weld anything on the bike, disconnect the spark plug cap, unplug the ignition, disconnect the kill switch, scrape the paint bare near the area to be welded and put the ground clamp as close to the area to be welded as possible.

⚠ WARNING

Be sure the fuel tank and carburetor have been removed and safely located away from the welding process.

The frame is a combination of HSLA steel and 4130 Chrome Moly and it is important to weld it with the proper rod and heat settings set as light as possible. Cobra recommends replacing the frame with a new one if the old one becomes damaged. Use ER70S6 filler if welding on the frame.

Replacing Transmission / Clutch Lubricant

Tools needed:

- 18 oz, of VP Racing SAE 80 Gear Lube
- 8 mm Allen wrench

CAUTION:

General automotive motor oil has frictional modifiers which will cause premature wear and failure of the clutch.

Procedure:

1. Begin this procedure with a bike that has been ridden more than 5 minutes but less than 10 minutes. It is desired to have the engine warm enough so that the oil is 'runny' but not so hot that there is risk of being burned by the engine or the oil.

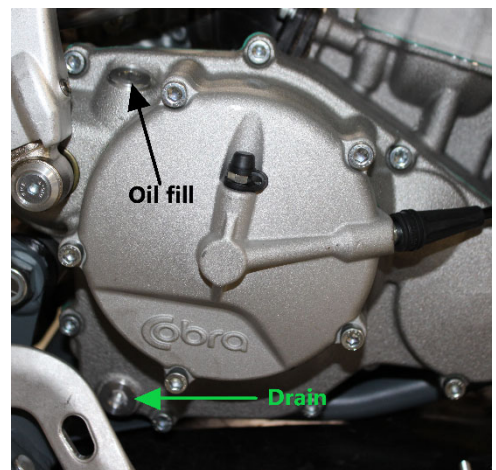

⚠ WARNING

Hot oil and hot components on the motorcycle may cause burns.

2. Lean the bike against something or set on stand with oil drain hole.
3. Using an 8mm Allen wrench, remove the oil drain bolt located on the right side of the engine, on the clutch cover, near the brake lever (See Figure 1).

NOTE: You may need to adjust the brake pedal (up or down) to gain access to the drain bolt.

4. After it has drained, reinstall the bolt being sure that the rubber gasket is in place. Torque to 11 Nm (8 ft-lb).
5. Remove oil fill plug with an 8mm Allen wrench.
6. Carefully pour 16 oz (470 ml) of transmission oil into the oil fill opening.
7. Reinstall the oil fill plug making sure the rubber gasket is in place.

NOTE: Filling after an engine rebuild required additional transmission fluid. If the engine is completely flushed of oil, refill with 18 oz (530ml).

⚠ WARNING

Always capture and dispose of used oil properly (all auto parts stores accept used oil). Dumping oil on the ground is illegal, inconsiderate, and can get you disqualified from a race weekend quicker than cutting the track.

Chain adjustment

Tools required for chain adjustment

- 22 mm wrench or socket
 - 2 - 11 mm open-end wrenches
1. Make sure that the rear wheel is aligned properly.
 2. For proper adjustment, the chain should have 35 mm free movement just behind the chain block with no load on the bike (Figure 2)

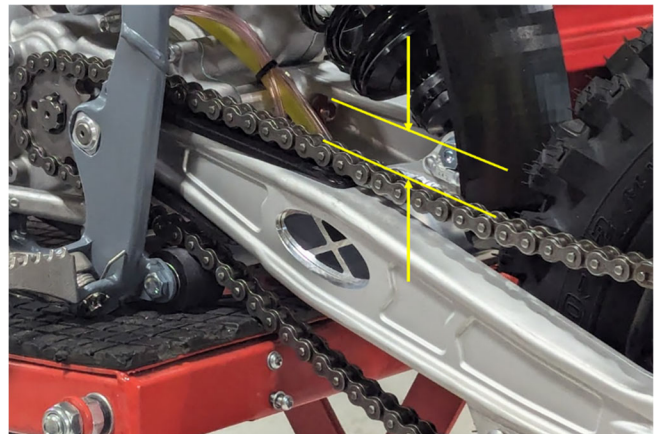

Figure 2

CAUTION: Sit on the bike and verify that the chain has a minimum of 12mm (1/2") free movement when the chain is at its tightest point.

3. If the chain requires adjusting, loosen the axle with a 22mm wrench, and loosen the jam nut with an 11mm wrench. Tighten the chain by rotating the adjuster bolts clockwise (CW) or loosen the chain by rotating the adjuster bolts (CCW).
4. Put a rag between the sprocket and chain, and roll the wheel backward to pull the chain adjuster blocks tightly against the adjuster bolts (Figure 3).



Figure 3

- Retighten the axle bolt to 25 ft-lb (34 Nm).
- Retighten the adjuster jam nuts.

CAUTION:

Always check rear brake adjustment and free-play after adjusting the chain.

Lever Adjustment

Tools required for chain adjustment

- 4mm Hex Wrench
- 8mm Open End Wrench

For lever position adjustment use a 4mm hex wrench and an 8mm open end wrench to adjust the socket head cap screw between the lever and the bars.

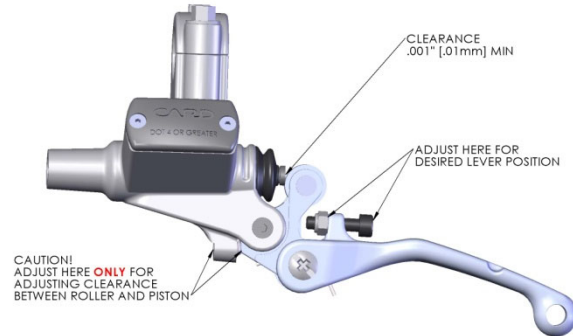

CAUTION:

The small set screw in the master cylinder housing controls freeplay/clearance between the piston and the roller. Improper adjustment of this screw will promote brake or clutch failure. This screw is preset at the factory. If it requires adjustment over time (as the screw tip makes an indentation in the aluminum) set it so that there is a minimal .001" (.001mm) clearance between the roller and the head of the piston (see figure).

Rear Brake Pedal Height

Brake pedal toe tip height can be adjusted with the nut and adjuster located below the rear brake master cylinder. The free-play is not adjustable on this model.

CAUTION: Use a New container of VP Racing: 622 DOT4 Racing Brake Fluid if necessary to add fluid.

Setting rear brake pedal position
(see figure 2b):

- Loosen the height adjust lock nut (10mm wrench)
- Adjust the height adjustment shaft (fingers on the threaded portion of the plunger) to raise or lower the pedal:
 - Standing riding position, and
 - Sitting riding position.
- Tighten the height adjust lock nut.

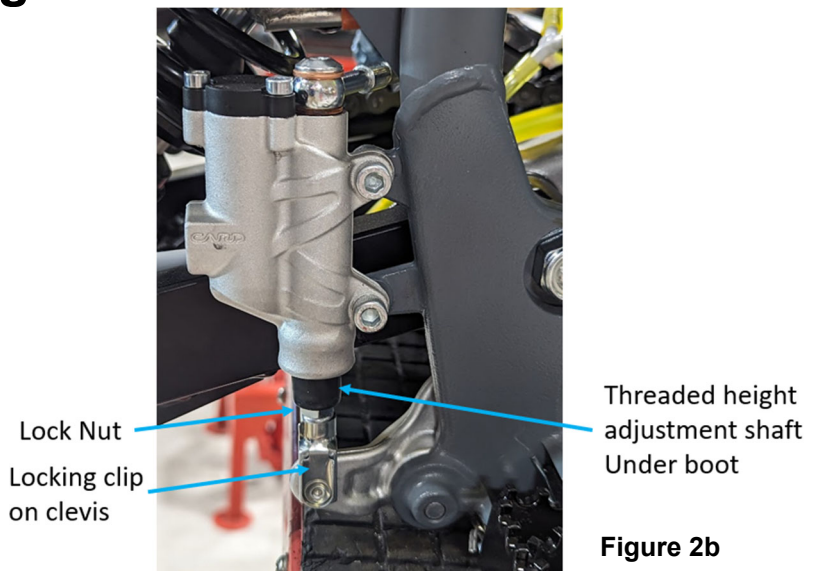

Figure 2b

NOTE: If it's not possible to rotate the threaded adjuster by finger, the next way would be to remove the clevis from the brake pedal by popping of the **Locking Clip**, use vice grips or similar on the threaded portion to keep it from rotating, and use a wrench on the square portion of the clevis that remains on the brake plunger

NOTE: Turning the clevis Clockwise will lengthen the adjuster (plunger), will raise the toe tip of the brake pedal, and turning the clevis Counter-Clockwise will shorten the adjuster (plunger) lowering the toe tip of the brake pedal.

⚠ WARNING

Make sure that the free play locking clip is installed such that one must push forward, toward the front of the bike, to remove. Otherwise the clip is apt to come undone while riding.

Air Filter Cleaning

Removal:

- Remove the seat
- Loosen the clamp connecting the rubber boot of the filter to the carburetor
- Push the rubber boot from the bottom up and out of the airbox

CAUTION: Pulling on the filter instead of pushing up on the boot may cause tearing of the filter.

NOTE: Using one hand to control the filter end while removing will help reduce the risk of damage to the filter

- Pull the tab on the filter to remove it from the rubber boot
- Clean the airbox of dirt.

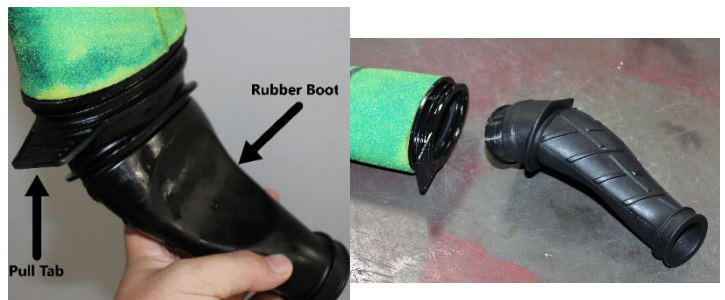

Cleaning:

CAUTION: Pay particular attention to clean any particles from the airbox between the filter location and the carburetor.

NOTE: Cobra has available a carburetor cover that allows easy cleaning of the airbox.

Carburetor Cover

CAUTION: Cleaning the air filter with alcohol or using filter oil that contains alcohol may cause filter glue separation.

1. Install the cover (RCMU0208) over the carburetor inlet
2. Spray out the airbox.

⚠ WARNING

Do not clean the air filter with gasoline or other highly volatile petroleum product. Diesel fuel or kerosene would be preferred but caution should still be taken. Hot soapy water works well.

1. Clean the filter in hot soapy water to remove all dirt particles.
2. Allow it to dry thoroughly.
3. Saturate with filter oil and remove excess.

NOTE: It's very important to oil your filter consistently each time because varied amounts of oil will change your carburetor jetting.

Assembly:

1. Place the filter back onto the rubber boot.
2. With one hand on the filter, feed the rubber boot into the airbox

CAUTION: In order to avoid air filter tearing, make sure to place a hand on the filter while feeding the boot through the airbox.

NOTE: Make sure you change or clean your filter after each moto. We recommend carrying multiple filters in your toolbox, one for each practice session and moto.



Fork Maintenance

Cobra strongly recommends that a professional service technician conduct all internal maintenance other than changing springs and oil. This will help to ensure safe and consistent operation.

For routine maintenance, the chart below provides suggested service intervals for common procedures:

	<u>Each Ride</u>	<u>10 hours</u>	<u>20 hours</u>	<u>As Needed</u>
<u>Bleed excess air</u>	<u>X</u>			
<u>Change Oil</u>		<u>X</u>		
<u>Change Seal/Swiper</u>			<u>X</u>	
<u>Change Bushings</u>				<u>X</u>

Fork Air Bleeding

Tools required

- 3mm hex key (Allen wrench)

During normal operation, both fork legs will build up air pressure. This pressure acts as an additional spring so it must be bled on a regular basis to maintain consistent suspension operation. Before each ride, loosen the socket head cap screw located at the front of each fork cap far enough so that any excess pressure in the leg is relieved. After excess air is bled off, retighten the screw to 5 in-lb. Be careful not to lose or damage the sealing ring that is located under the head of each bleed screw.

Fork Oil Replacement

Tools required

- 37mm Fork Cap Tool (MCMUTL37)
- 22mm closed-end wrench or socket
- 14mm open-end wrench
- Drift punch (12mm OD x 300mm long (1/2" x 12"))
- 5 & 6 mm hex key (Allen wrench)
- Mallet
- 5 wt. VP Racing fork oil



Disassembly procedure

1. Remove the front wheel.
 - a. Loosen the brake-side axle pinch bolts (5mm hex key)

- b. Carefully remove the brake side axle cap using a closed-end wrench to protect the cap from damage. (22mm wrench)
 - c. Loosen the non-brake side axle pinch bolts (5mm hex key)
 - d. Using the drift punch (a long 3/8 socket extension will also work), remove the axle from the fork lugs by placing the punch inside the hollow axle and tapping lightly on the exposed end with the mallet.
 - e. Carefully slide with wheel downward out of the brake caliper.
2. Remove the brake caliper from the fork leg (6mm hex key).
 3. Loosen the fork caps (Cobra 37mm Fork Cap Tool).
 4. Remove the fork legs from the triple clamps (5mm hex key).
 5. One leg at a time:
 - a. Remove the fork cap from the fork tube.
 - b. Lower the fork tube to expose the fork spring.
 - c. Pull the fork spring down from the fork cap to expose the damper rod lock nut. Secure this nut using a 14mm wrench.
 - d. With the 14mm wrench on the damper rod nut, use the 37mm fork cap wrench to free the fork cap from the damper rod.
 - e. Remove the 14mm wrench and allow the damper rod to fall into the cartridge tube.
 - f. Remove the fork spring.
 - g. Invert the fork to allow the oil to drain. Pump the damper rod assembly several times to help any excess oil trapped in the cartridge to drain.

Assembly procedure

1. Completely collapse the outer fork tube onto the stanchion tube.
2. Pump the damper rod up and down slowly to help the assembly fill with oil.
3. Install the fork spring.
4. Use a flexible retrieving tool to pull the damper rod up through the fork spring and thread the damper rod into the fork cap.

CAUTION:

Ensure that the fork cap is completely threaded onto the damper rod before it makes contact with the lock nut.

5. Pull the fork spring down from the cap and torque the damper rod lock nut to 15 N-m (11ft-lb) with a 14mm wrench.

CAUTION:

The damper rod is hollow and will break if the nut is over tightened.

6. Ensure that the fork cap O-ring is in good condition, Use the 37mm fork cap wrench to secure the fork cap to the fork outer tube. Torque the fork cap to 20 Nm (15 ft-lb).
7. Pump the fork leg several times to verify that it operates smoothly.
8. Install each leg back into the triple clamp. Torque each pinch bolt to 11N-m (8 ft-lb) making sure both legs are set to the same height in the clamps.
9. Reinstall the brake caliper.

10. Reinstall the front wheel.

1. Install axle through non-brake side fork lug and wheel hub
2. Slide wheel spacer over axle taking care to ensure that the internal O-ring is in place.
3. Continue sliding axle through brake-side lug and reinstall axle cap (6 ft-lb, 8 Nm)
4. Lightly torque all four axle pinch bolts
5. Drop the bike onto the ground, engage the front brake, and push up and down on the handlebars several times to ensure that the front forks and the front wheel are properly aligned with each other.
6. Apply final torque to all four axle pinch bolts (7.4 ft-lb, 10 Nm)

Ignition Timing

The ignition timing value for the CX65 is 0° retarded from the standard base reference (0°). This can be verified by removing the ignition cover and looking as shown in the figure below.

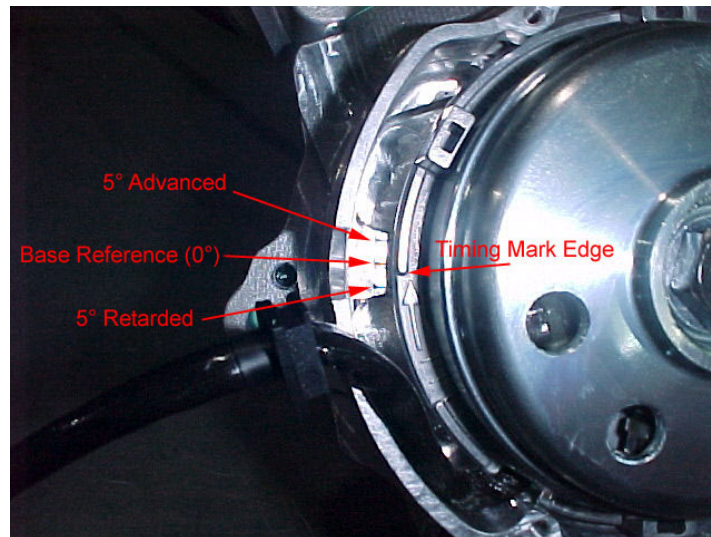

The center mark on the cases is the standard base reference timing mark (0°), and the other two large marks are 5° advanced and retarded. The small timing marks between 0 & 5° is 2.5°.

To change the timing, one must remove the flywheel with Cobra 65 flywheel puller # MCMUTL05. After the flywheel has been removed, the timing can be adjusted by loosening the stator bolts and rotating the stator to the desired position.

Parts

Parts – Air Box & Inlet System

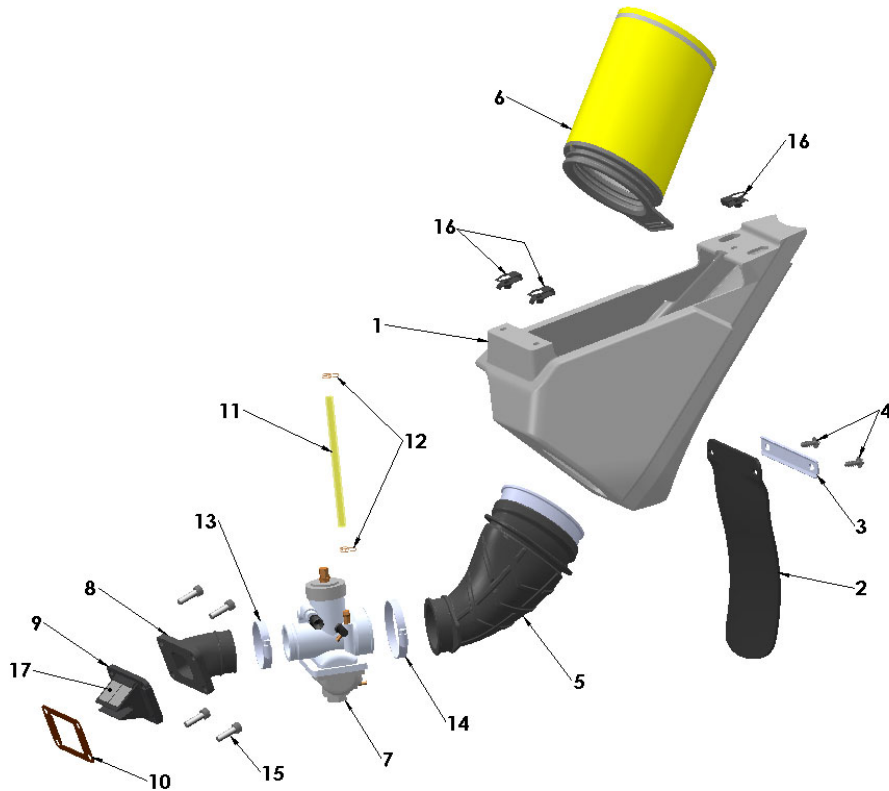

Air Box & Inlet		
REF #	PART #	DESCRIPTION
1	RCC60028	AIRBOX
2	TCC60008	MUD FLAP
3	TCC60125	BRACKET - MUDFLAP
4	HCSP0004	SCREW – PLASCREW
5	RCC60027	AIR BOOT
6	RCC60029	AIR FILTER
7	RCR60026	CARBURETOR 26mm MIKUNI
8	ECC60240	INTAKE MANIFOLD
9	ECC60006	REED ASSEMBLY
10	ZCC60021	GASKET, REED
11	FCMU0026	FUEL LINE
12	MCMUCL04	HOSE CLAMP, 8mm
13	MCKGHO01	HOSE CLAMP, MANIFOLD TO CARB
14	MCKGHO03	HOSE CLAMP, AIR BOOT TO CARB
15	HCBC0625	M6 x 25mm SHCS
16	HCHA0003	CLIP NUT, M6
17	ECC60014	REED PETALS – REPLACEMENT
accessory	RCMU0208	INLET COVER – 65 CARB

Parts – Bars and Controls

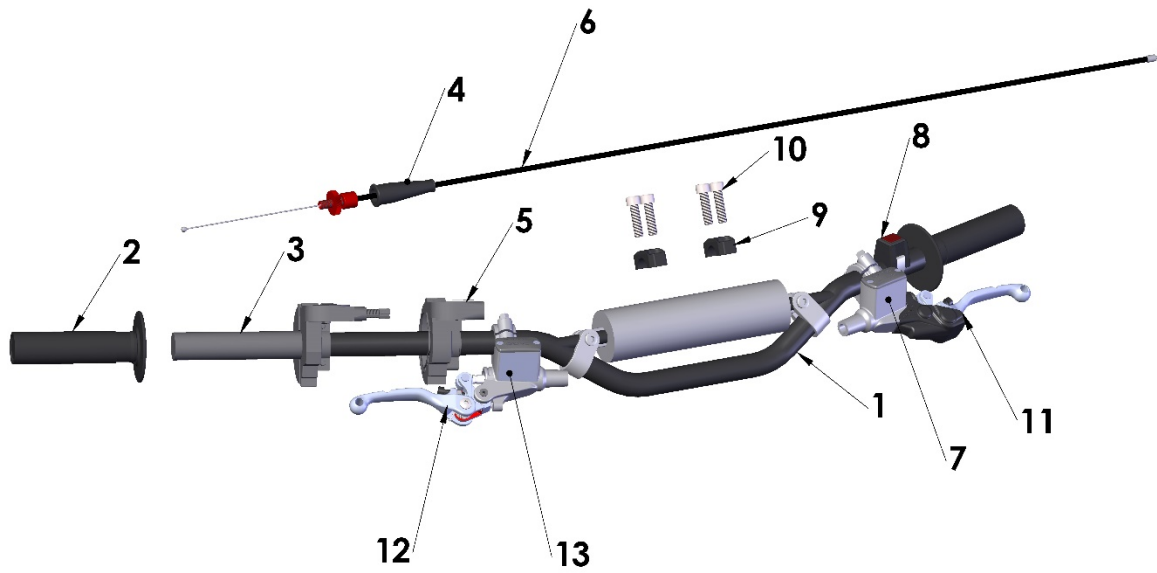

Bars and Controls		
REF #	PART #	DESCRIPTION
1	FAC60023	HANDLEBARS – PROTAPER CX65
2	TCC60035	GRIPS – PROTAPER (SET OF TWO)
3	FCMU0043	THROTTLE ASSEMBLY
	FCMU0042	TUBE – THROTTLE
4	FCPW0004	CABLE COVER
5	FCMU0021	THROTTLE COVER
6	RAC60001	THROTTLE CABLE
7	CCC60022	MASTER CYLINDER ASSEMBLY – MAGURA – W LEVER
8	FCMU0033	KILL SWITCH ASSEMBLY
9	TCMU0060BLK	BAR CLAMP – BLACK - FORGED
10	HCBC1035	M10X35mm SOCKET HEAD CAP SCREW (2 REQ'D)
11	HCNL1001	M10 LOCK NUT
9	TCMU0060BLK	BAR CLAMP - BLACK
10	HCBC0806	M8 X 30 SOCKET HEAD CAP SCREW (4 REQ'D)
11	CCC60034	LEVER – CLUTCH – MAGURA
12	CKC60004	LEVER ASSY – BRAKE - CARD
13	BAC60010	MASTER CYLINDER ASSEMBLY - BRAKE - WITH LEVER
15	HCBC0812	M8 X 12 SHCS - LOW PROFILE (2 REQ'D)
	MCMU0001	PAD – CROSS BAR
ACCESSORY	BKC60015	REBUILD KIT – MASTER CYLINDER - BRAKE - ZL
ACCESSORY	CCC60038	REBUILD KIT – CLUTCH MASTER CYLINDER - MAGURA

Parts - Carburetor

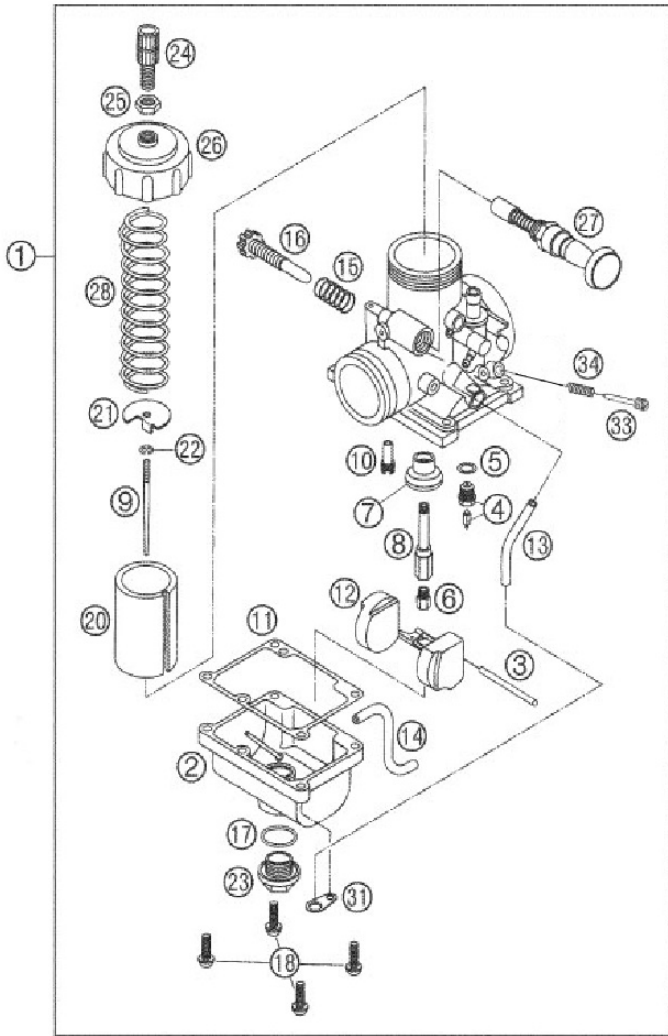

Carburetor		
REF. #	PART #	DESCRIPTION
1	RCR60026	CARBURETOR 26MM MIKUNI
2	RCC60017	FLOAT BOWL CHAMBER
4	RCMU0271	NEEDLE VALVE & SEAT ASSY
6	SEE BELOW	MAIN JET
9	RCEX0026	NEEDLE JET STOCK 5L14
10	SEE BELOW	PILOT JET
11	RCC60013	GASKET, FLOAT BOWL
15	RCEX0016	SPRING IDLE ADJUST SCREW
16	RCEX0015	IDLE ADJUST SCREW
17	ZCDCOR01	O'RING BOWL PLUG
18	RCEX0012	FLOAT BOWL SCREW
20	RCC60025	SLIDE
21	RCC60016	SLIDE STUFFER
22	RCMU0277	CLIP - NEEDLE
24	RCEX0005	ADJUSTER
25	RCEX0006	LOCK NUT
27	RCC60026	CHOKE ASSY
33	RCEX0013	AIR ADJUSTING SCREW
34	RCEX0014	SPRING - AIR ADJUST SCREW
NOT SHOWN	RCMU0415	CABLE ADJUSTER CAP (RUBBER)
	RCC60021	AIR SCREW O-RING
	RCC60020	AIR SCREW WASHER

PILOT JET		MAIN JET	
30	RCEX0030	190	RCMU0190
32.5	RCEX0032	195	RCMU0195
35	RCEX0035	200	RCMU0200
37.5	RCEX0037	205	RCMU0205
40	RCEX0040	210	RCMU0210
42.5	RCEX0042	215	RCMU0215
45	RCEX0045	220	RCMU0220
47.5	RCEX0047	230	RCMU0230
50	RCEX0050	240	RCMU0240
52.5	RCEX0052	250	RCMU1250
55	RCEX0055	260	RCMU1260
57.5	RCEX0057	270	RCMU1270
60	RCEX0060	280	RCMU1280
		290	RCMU1290
		300	RCMU1300
		310	RCMU1310

Parts – Clutch – Master Cylinder

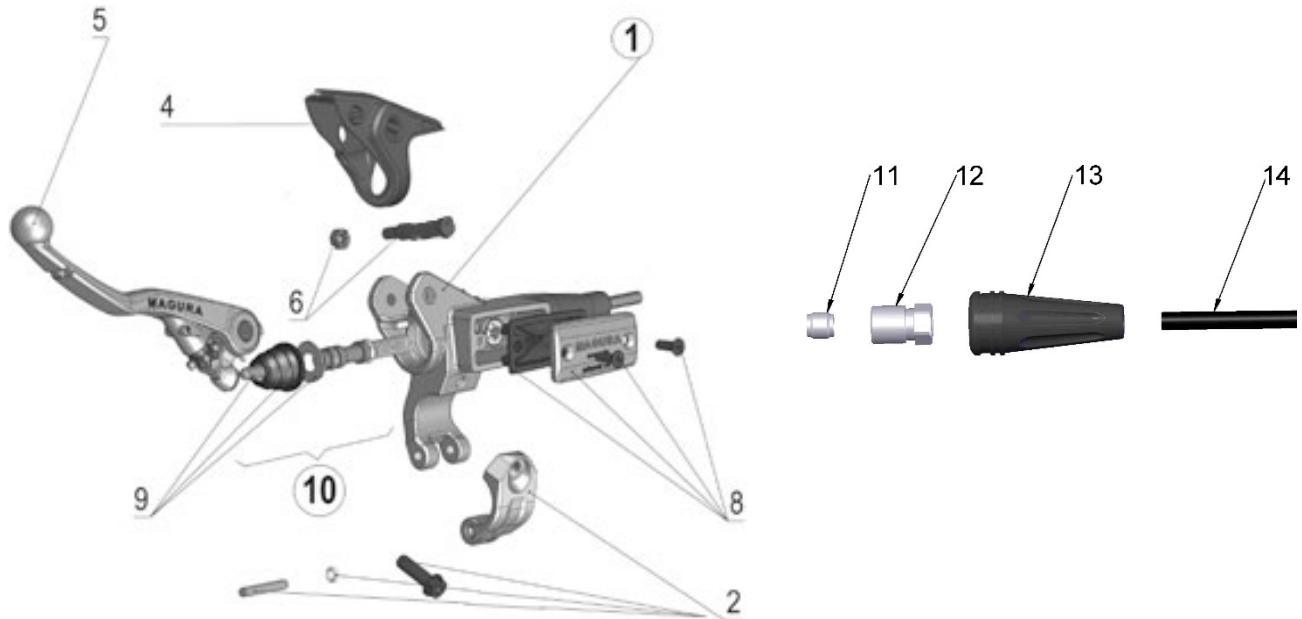

Clutch – Master Cylinder		
REF#	PART #	DESCRIPTION
1	CCC60022	MASTER CYLINDER – CLUTCH – MAGURA
2	CCC60033	CLAMP W/PIN – CLUTCH MASTER CYLINDER
4	CCC60039	COVER – CLUTCH LEVER PIVOT - MAGURA
5	CCC60034	LEVER – MAGURA CLUTCH
6	CCC60035	SCREW & NUT – CLUTCH LEVER – MAGURA
8	CCC60037	COVER – CLUTCH RESERVOIR – MAGURA MINERAL OIL
9	CCC60036	PUSH ROD & BELLOWS - CLUTCH LEVER - MAGURA
10	CCC60038	REBUILD KIT – CLUTCH MASTER CYLINDER 9.5
11	BCMU0017	FERRULE – COMPRESSION FITTING
12	BCMU0020	FITTING – THREADED CLUTCH LINE END
13	BCMU0021	COVER – FOR SLEEVE NUT
14	CCC60041	LINE – CLUTCH - REPLACEMENT KIT – FORGED COVER
		(LINE & 2 FERRULES)

Parts – Cooling System

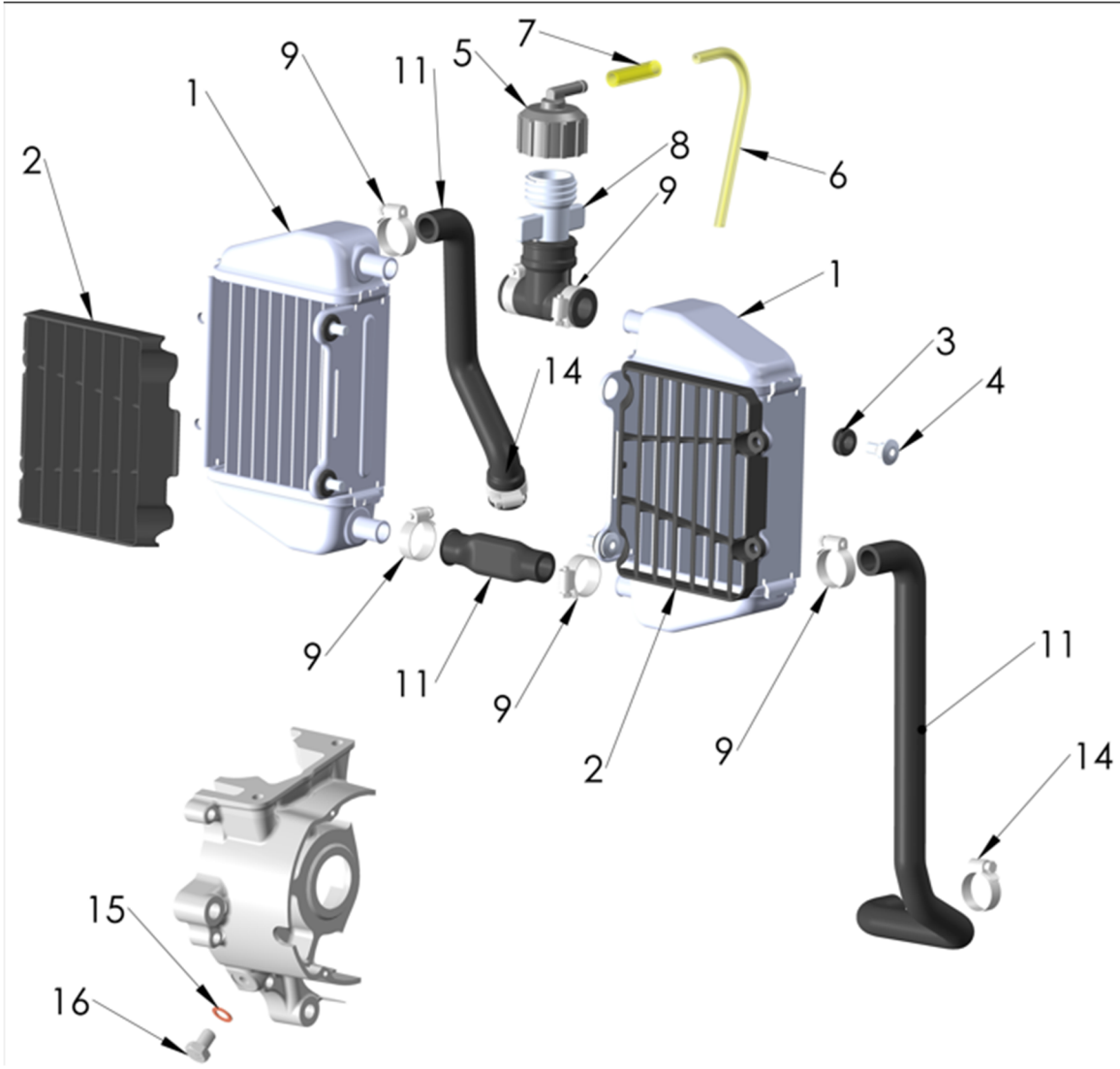

Coolant System		
REF #	PART #	DESCRIPTION
1	FCMU0081	RADIATOR (2 REQ'D)
2	FCMU0069	LOUVER (2 REQ'D)
3	MCMUGR12	GROMMET – RADIATOR MOUNTING (4 REQ'D)
4	HCSP0610	FASTENER – RADIATOR MOUNTING (4 REQ'D)
5	FCMU0020	CAP, 1.3 BAR
6	FCMU0113	HOSE, RADIATOR OVERFLOW, 22"
7	FCMU0322	HOSE – USED AS CLAMP
8	FCMU0036M	"T" FITTING – COOLANT – WITH CAP
9	MCMUCL09	HOSE CLAMP – 11 TO 22mm (6 REQ'D)
11	FKC60003	HOSE SET - SILICONE - BLACK
14	MCMUCL07	HOSE CLAMP – 14 TO 27mm (2 REQ'D)
15	HCBH0805	BOLT – COOLANT DRAIN
16	HCWC0000	GASKET – COOLANT DRAIN
ACCESSORY	FKC60003RED	HOSE SET - SILICONE - RED

Parts – Electrical System

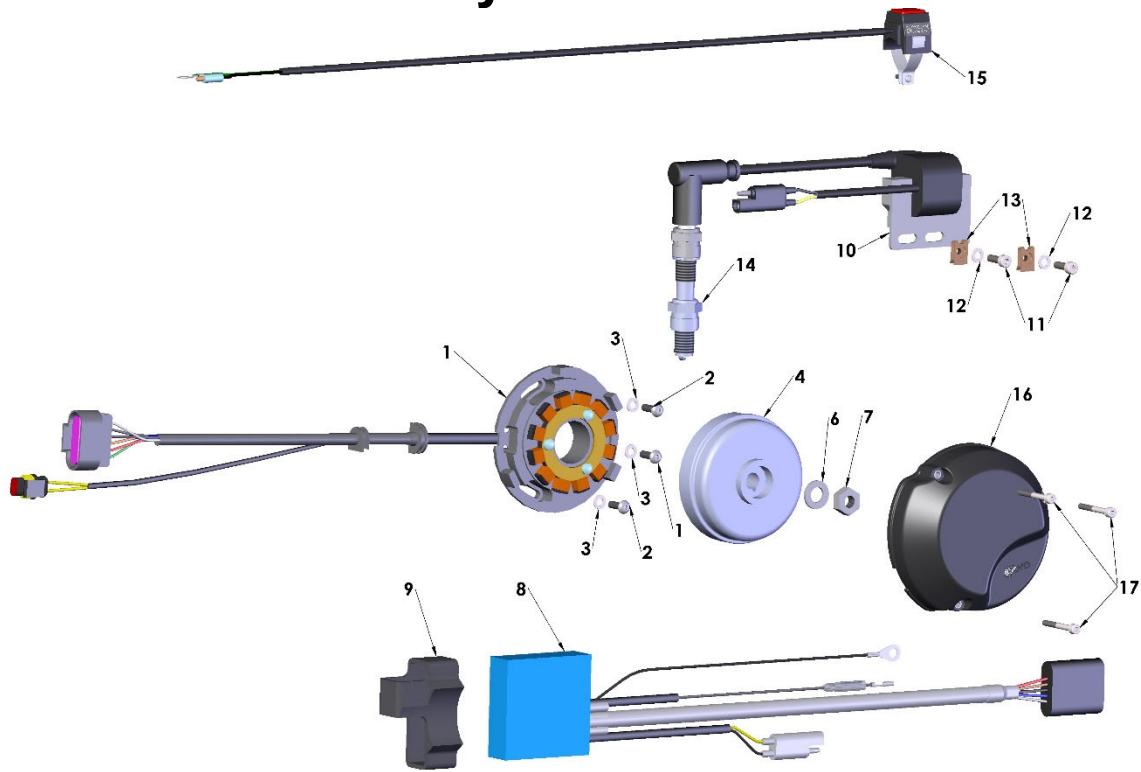

Electrical System		
REF #	PART #	DESCRIPTION
1	ICC60018	STATOR – POWER VALVE CX65 - FANG
2	HCBT0516	M5X16mm TORX HEAD SCREW (3 REQ'D)
3	HCWF0501	5mm FLAT WASHER (3 REQ'D)
4	ICC60007	ROTOR OUTER STYLE CX65
5	ICMU0012	WOODRUFF KEY (NOT SHOWN)
6	HCWF0010	10mm FLAT WASHER
7	HCNS1001	M10 NUT
8	ICC60019	CDI UNIT – POWER VALVE CX65 - FANG
9	ICMU0035	MOUNT – CDI
10	ICC60005	COIL DIGITAL 65
11	HCBC0514	M5X14mm SOCKET HEAD CAP SCREW – COIL MOUNTING (2 REQ'D)
12	HCWF0501	5mm WASHER – COIL MOUNTING (2 REQ'D)
13	HCCN0000	5mm EXTRUDED “U” NUT – COIL MOUNTING (2 REQ'D)
14	ECMU0033C	SPARK PLUG
15	FCMU0033	KILL SWITCH ASSEMBLY
16	ECC60166	COVER – IGNITION
17	HCBC0402	M4X35mm SOCKET HEAD CAP SCREW – COVER MOUNTING (3 REQ'D)
NOT SHOWN	FCMU0030	COVER – KILL SWITCH SCREW
ACCESSORY	ICMU0016	SPARK PLUG CAP 5K Ω
ACCESSORY	MCKGGR00	GROMMET WIRE PROTECTION (2 PLACES)
TOOLS	MCMUTL05	PULLER – FLYWHEEL
TOOLS	MCMUTL19	HARNESS – DIAGNOSTIC BREAKOUT

Parts – Engine Clutch

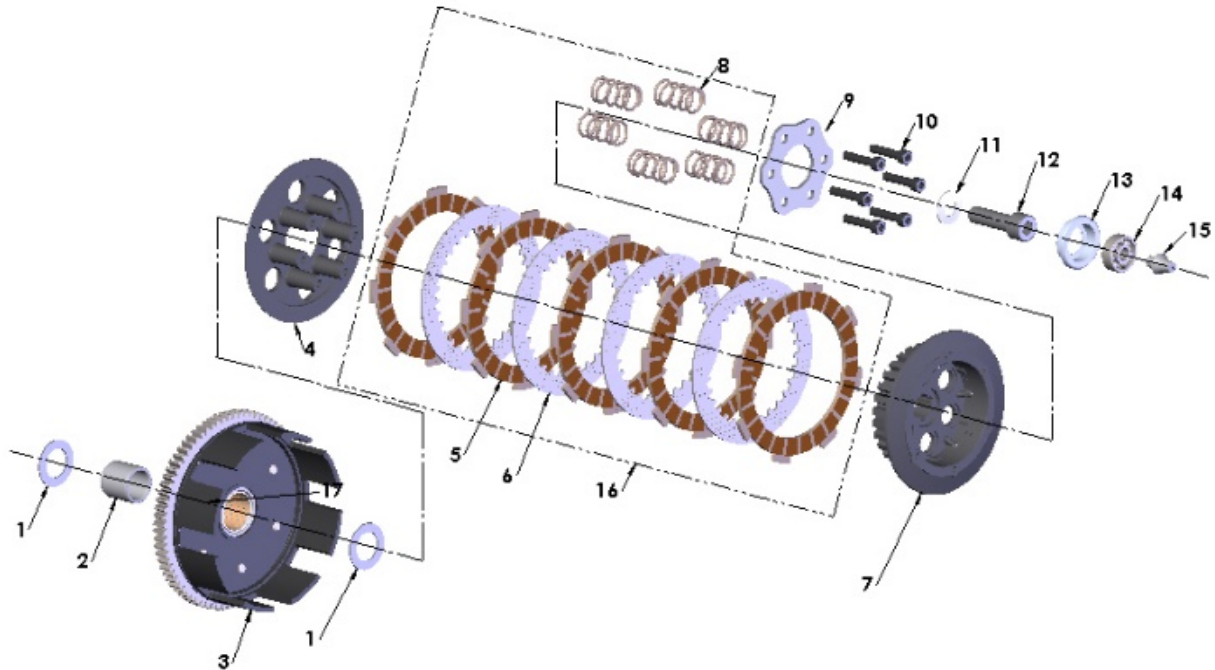

Clutch Components		
REF. #	PART #	DESCRIPTION
1	ECDC0063	CLUTCH WASHER (2 REQ'D)
2	ECDC0064	CLUTCH BUSHING – INNER / STEEL
3	EAEX0003	CLUTCH BASKET ASSEMBLY (INCLUDES ECDC0167)
4	ECDC0066	CLUTCH PRESSURE PLATE
5	ECDC0068W	CLUTCH DISC-FRICTION – (5 REQ'D)
6	ECDC0067	CLUTCH DISC-STEEL – (4 REQ'D)
7	ECDC0069	CLUTCH HUB
8	ECDC0070	SPRING, CLUTCH – (6 REQ'D)
9	ECDC0071	PLATE, CLUTCH SPRING
10	HCBC0525	M5X25mm SOCKET HEAD CAP SCREW (6 REQ'D)
11	ECDC0030	SPRING WASHER – CLUTCH
12	HCBF1030	M10X30mm FLANGE HEAD BOLT
13	ECDC0019	CLUTCH BEARING SEAT
14	ECDC0018	BEARING, CLUTCH THROW OUT
15	ECC60190	PUSH ROD – CLUTCH 2015
16	CKMU0001	CLUTCH KIT INCLUDING – SPRINGS, STEELS AND FIBERS
17	ECDC0167	CLUTCH BUSHING – OUTER / BRONZE (REPLACEMENT)
ACCESSORY	CKC60002	CLUTCH BASKET REPLACEMENT KIT

Parts – Engine – Clutch / Kick Cover

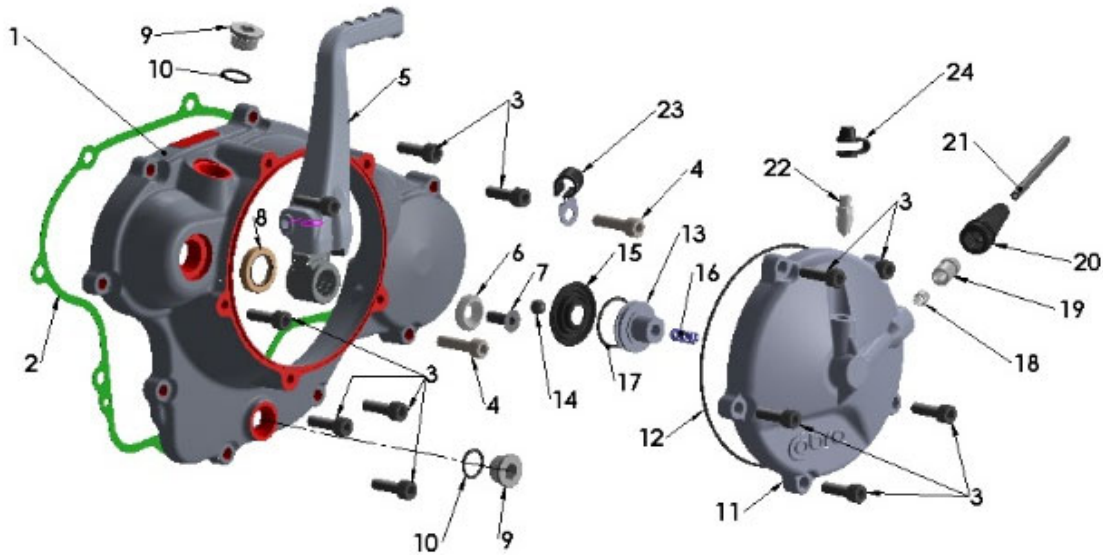

Clutch / Kick Cover Components		
REF. #	PART #	DESCRIPTION
1	ECC60239	COVER – CLUTCH
2	ZCC60016	GASKET – CLUTCHCOVER
3	HCBC0620	M6X20mm SOCKET HEAD CAP SCREW (12 TOTAL REQ'D) (7 REQ'D FOR CLUTCH COVER, 5 REQ'D FOR CLUTCH CAP)
4	HCBC0625	M6X25mm SOCKET HEAD CAP SCREW (2 REQ'D)
5	EAMU0011	LEVER ASSEMBLY – KICKSTARTER
6	ECMU0250	WASHER – KICK LEVER
7	HCFH0616	M6X16mm FLAT HEAD CAP SCREW
8	ECDC0078	SEAL – KICKSTARTER
9	ECMU0272	OIL FILL PLUG, ALUMINUM
10	ZCMUB014	O-RING – OIL FILL PLUG
11	ECC60179	CLUTCH COVER CAP - CX65 2015 -
12	ZCC60013	O-RING – CLUTCH CAP
13	CCC60005	PISTON – CLUTCH SLAVE CYLINDER
14	CCEX0009	BALL – CLUTCH ENGAGEMENT
15	CCC60007	BELLOWS – CLUTCH SLAVE
16	CCC60006	SPRING – SLAVE RETURN
17	ZCMUOR35	O-RING – SLAVE PISTON – MINERAL OIL
18	BCMU0017	FERRULE – COMPRESSION FITTING
19	BCMU0020	FITTING – THREADED CLUTCH LINE END
20	BCMU0021	COVER – RUBBER CLUTCH LINE END
21	CCC60040	LINE – CLUTCH REPLACEMENT
22	BCMU0018	FITTING – BLEED, CLUTCH LINE
23	CCC60030	CLAMP – CLUTCH LINE
24	BCC60034	CAP - BLEED SCREW
ACCESSORY	EKMU0002	PIVOT SPRING, BALL AND SET SCREW KIT – KICK STARTER

Parts – Engine – Ignition Side

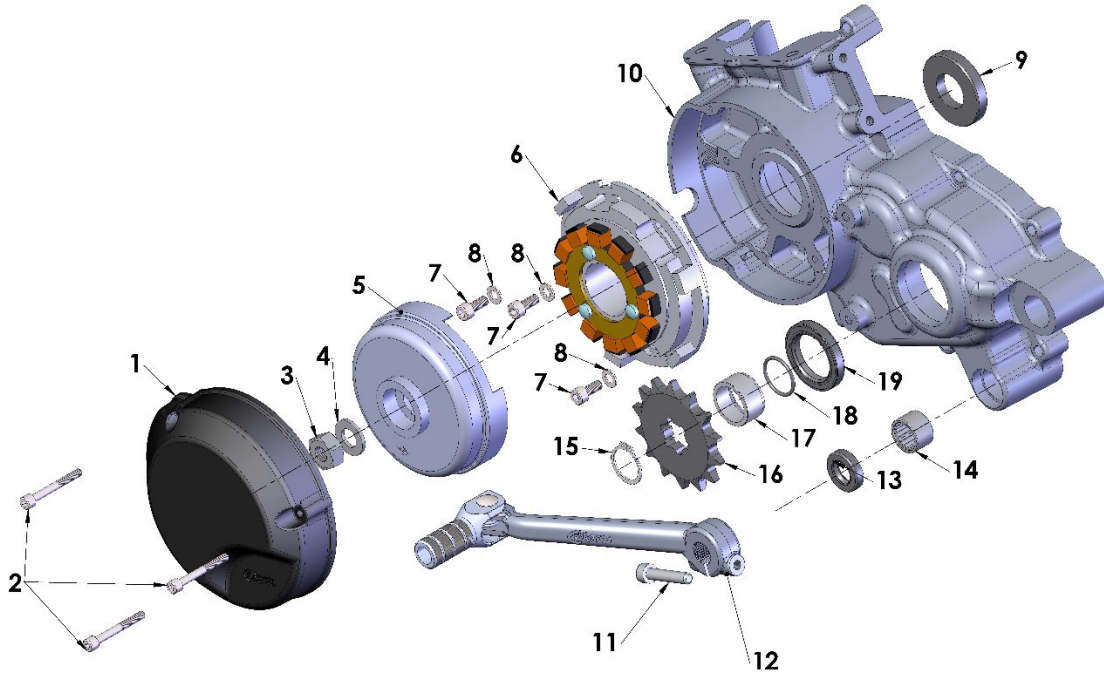

Ignition Side Engine Components		
REF. #	PART #	DESCRIPTION
1	ECC60166	IGNITION COVER
2	HCBC0402	M4X35mm SOCKET HEAD CAP SCREW (3 REQ'D)
3	HCNS1001	M10 NUT
4	HCWF0010	10mm FLAT WASHER
5	ICC60007	ROTOR PVL OUTER STYLE
6	ICC60014	STATOR PVL DIGITAL – POWER VALVE CX65
7	HCBT0516	M5X16mm BUTTON HEAD TORX (3 REQ'D)
8	HCWF0501	5mm WASHER FLAT (3 REQ'D)
9	ECDC0024	SEAL, CRANKSHAFT
10	EKC62024	ENGINE CASE SET W/B&S CX65 – 2024 AND NEWER
11	HCBC0630	M6X30mm SHCS
12	ECC60250	SHIFTER LEVER – ALUMINUM - LONGER
13	ECC60254	SEAL, SHIFTER 12.7
14	ECC60253	BEARING, SHIFTER SHAFT 12.7
15	ECKGSR03	SNAP RING – OUTPUT - COBRA
16	PCKG00xx	xx DENOTES TEETH – RANGE OF TEETH (13-16)
16	PCKG0013	SPROCKET 13T
16	PCKG0014	SPROCKET 14T
16	PCKG0015	SPROCKET 15T
17	ECDC0009	SPACER, SPROCKET
18	ZCMUOR26	O-RING, SPROCKET SPACER – THICKER - 2022
19	ECDC0025	SEAL, OUTPUT

Parts – Engine – Kick Mechanism & Water Pump

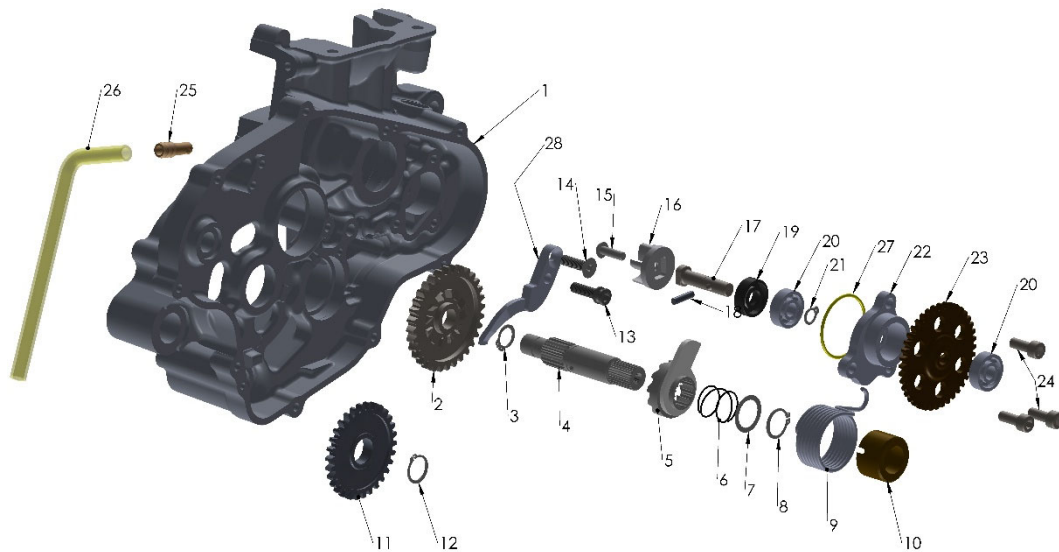

Kick Mechanism		
REF. #	PART #	DESCRIPTION
1	EKC62024	CRANKCASE – SET WITH BEARINGS & SEALS
2	ECDC0033	GEAR, KICKSTART
3	ECDC0035	SNAP RING, EXTERNAL 12mm
4	ECC60203	SHAFT, KICK STARTER – THREADED
5	ECC60201	GEAR – KICK RAMP - NO ARM
6	ECDC0042	SPRING, KICKSTART RAMP
7	ECDC0043	WASHER, KICKSTART BACKUP
8	ECDC0036	SNAP RING, EXTERNAL 16mm - SPRING RET.
9	ECC60067	SPRING – KICK RETURN CX65
10	ECC60202	SPACER – KICK SPRING CENTERING - 2015
11	ECDC0032	GEAR, KICK START IDLE
12	ECDC0037	SNAP RING, EXTERNAL 15mm
13	ECMU0174	HOLDER – SPRING 20MM
14	HCFH0616	M6 X 16 FLAT HEAD SCREW
15	HCBB0403	M4 X 8 BUTTON HEAD
16	ECKG0073	IMPELLER – WATERPUMP
17	ECC60173	SHAFT – WATERPUMP
18	ECDC0051	PIN – DOWEL
19	ECC60175	SEAL – WATERPUMP
20	ECC60174	BEARING – WATERPUMP
21	ECC60176	SNAP RING – 8MM SHAFT
22	ECC60177	HOUSING – WATERPUMP
23	ECC60172	GEAR – WATERPMP DRIVE
24	HCBC0601	M6 X 16 SOCKET HEAD CAP SCREW (3 REQ'D)
25	ECMU0233	FITTING, VENT HOSE
26	ECMU0534	VENT HOSE
27	ZCMUOR07	O’RING – WATER PUMP
28	ECC60200	RAMP W STOP - KICK MECHANISM

Parts – Engine – Shift Mechanism

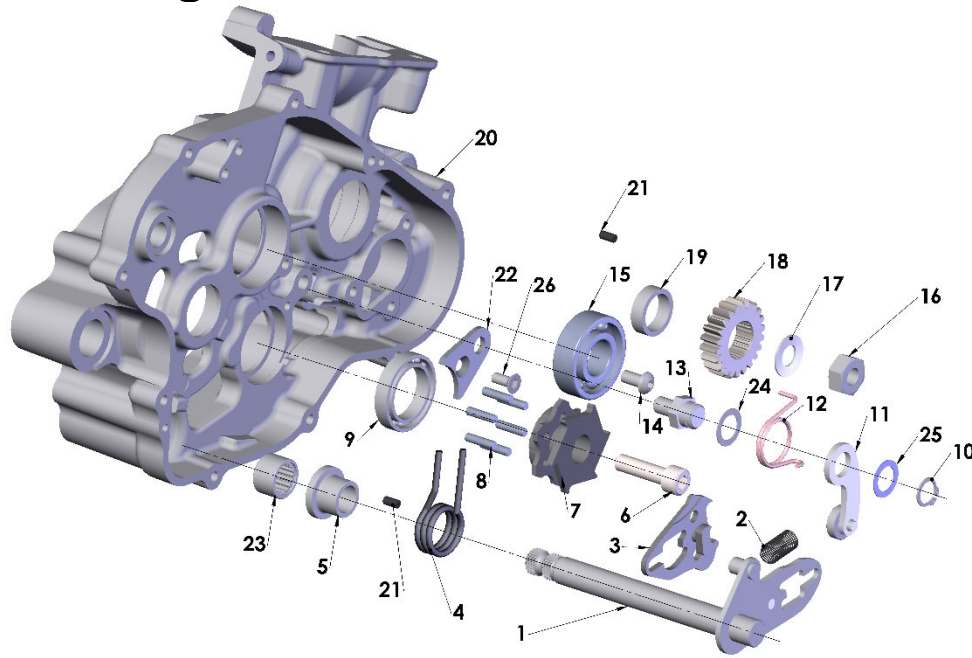

Shifting Components		
REF #	PART #	DESCRIPTION
1	EAC60040	SHAFT – SHIFTER W/ PIVOT PLATE
2	ECDC0055	SPRING – SHIFTER PLATES
3	EAC60018	PLATE – SHIFT SLIDING
4	ECC60124	SPRING – SHIFTER SHAFT CENTERING
5	ECC60258	BUSHING – SPRING CENTERING
6	HCBC0806	M8X30mm SOCKET HEAD CAP SCREW (BLACK OXIDE)
7	ECC60189	CASSETTE – SHIFT (W/O PINS)
8	ECDC0051	DOWEL – SHIFT CASSETTE (6 & 1 REQ'D)
9	ECDC0022	BEARING – SHIFT DRUM
10	ECDC0035	CLIP – ARM RETAINER
11	ECMU0545	ARM ASSY – SHIFT FOLLOWER
12	ECMU0546	SPRING – SHIFT FOLLOWER ARM
13	ECC60096	PIVOT – SHIFT ARM
14	HCBF2612	M6X12mm FLANGED BUTTON HEAD BLACK OXIDE
15	ECMU0216	BEARING – PRIMARY SHAFT CLUTCH SIDE
16	HCNS1001	NUT – M10 X 1.25
17	ECDC0030	BELLEVILLE – LOCK WASHER - 10MM
18	ECDC0073	GEAR – CRANK DRIVE
19	ECC60198	SPACER – CRANK DRIVE GEAR
20	EKC62024	CRANKCASE – SET WITH BEARINGS & SEALS
21	ECDC0053	DOWEL – CLUTCH COVER POSITION (2 REQ'D)
22	ECC60095	PLATE – BEARING RETAINER
23	ECC60253	BEARING – SHIFTER SHAFT 12.7
24	ECC60119	SHIM WASHER
		(NOTE MEASURE SHIM TO ORDER CORRECT SIZE)
25	ECC60152	SHIM 0.2mm THICK
25	ECC60153	SHIM 0.3mm THICK
26	HCFH0512	M5 X 12mm FLAT HEAD SCREW
NOT SHOWN	ECC60028	COLLAR – SWINGARM PIVOT

Parts – Engine – Top End

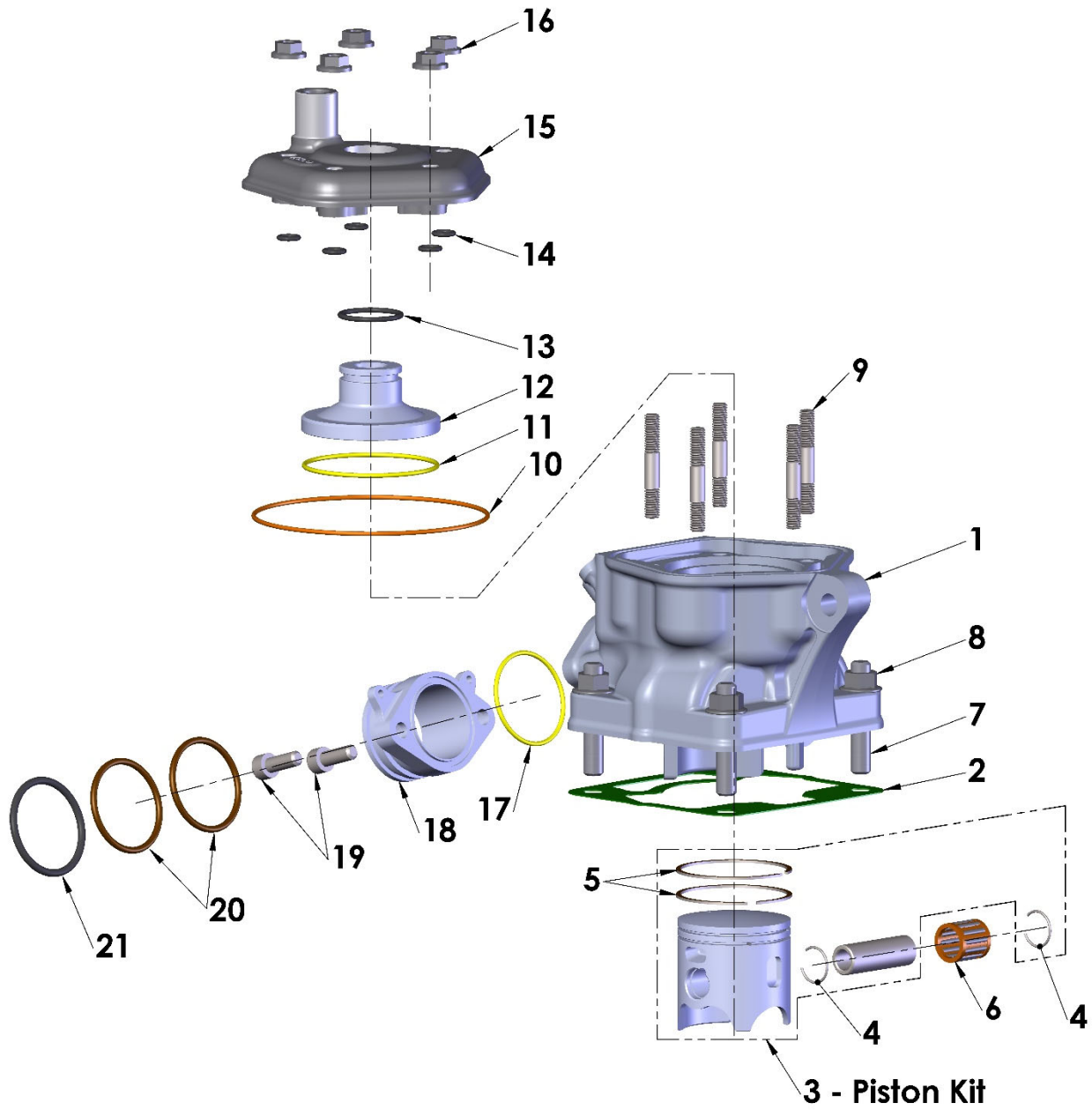

Engine – Top End		
REF #	PART #	DESCRIPTION
1	ECC60558	CYLINDER KIT PV CX65 (INCLUDES PISTON KIT & CYLINDER)
2	ZCC62402	BASE GASKET 0.2mm THICK
2	ZCC62403	BASE GASKET 0.3mm THICK
2	ZCC62404	BASE GASKET 0.4mm THICK
2	ZCC62405	BASE GASKET 0.5mm THICK
2	ZCC62406	BASE GASKET 0.6mm THICK
2	ZCC62407	BASE GASKET 0.7mm THICK
2	ZCC62408	BASE GASKET 0.8mm THICK
3	ECC60208x	PISTON KIT (x DENOTES PISTON SIZE A,B, or C)
	ECC60208WP	WRIST PIN – PISTON – 44.5MM CAST
4	ECC60222	SNAP RING FOR PISTON (2 REQ'D)
5	ECC60221	PISTON RINGS 44.5mm (2 PER SET)
6	ECDC0061	BEARING, WRIST PIN
7	ECC60109	STUD, CYLINDER 8mm (4 REQ'D)
8	HCFN0801	M8 FLANGE NUT (4 REQ'D)
9	ECC60107	STUD, CYLINDER 6mm (5 REQ'D)
10	ZCC60009	O-RING – GASKET LARGE PV HEAD OUTER
11	ZCMUOR05	O-RING CYLINDER HEAD MEDIUM - YELLOW
12	ECC60207	CYLINDER HEAD INSERT
13	ZCMUOR23	O-RING CYLINDER HEAD SMALL
14	ZCMUOR03	O-RING CYLINDER STUD - YELLOW (5 REQ'D)
15	ECC60149	CYLINDER HEAD OUTER
16	HCFN0601	M6 FLANGE NUT (5 REQ'D)
17	ZCMUOR07	O-RING, EXHAUST FLANGE TO CYLINDER
18	ECMU0262	FLANGE – EXHAUST
19	HCBC0612	M6X12mm SOCKET HEAD CAP SCREW (2 REQ'D)
20	ZCMOTE11	O-RINGS – PIPE TO FLANGE (2 REQ'D)
21	ZCMUOR11	O-RING – PIPE to FLANGE (1 REQ'D)
NOT SHOWN	ZKMUOR14	O-RING KIT – TOP END – CX65 PV
	ZKC62024	GASKET KIT – COMPLETE ENGINE
	EAC62024	COMPLETE ENGINE – 2024
	EKC62401A,B,C	REBUILD KIT INCLUDES ITEMS 2, 3, 6, 10, 11, 13, & 14

Parts – Engine – Transmission

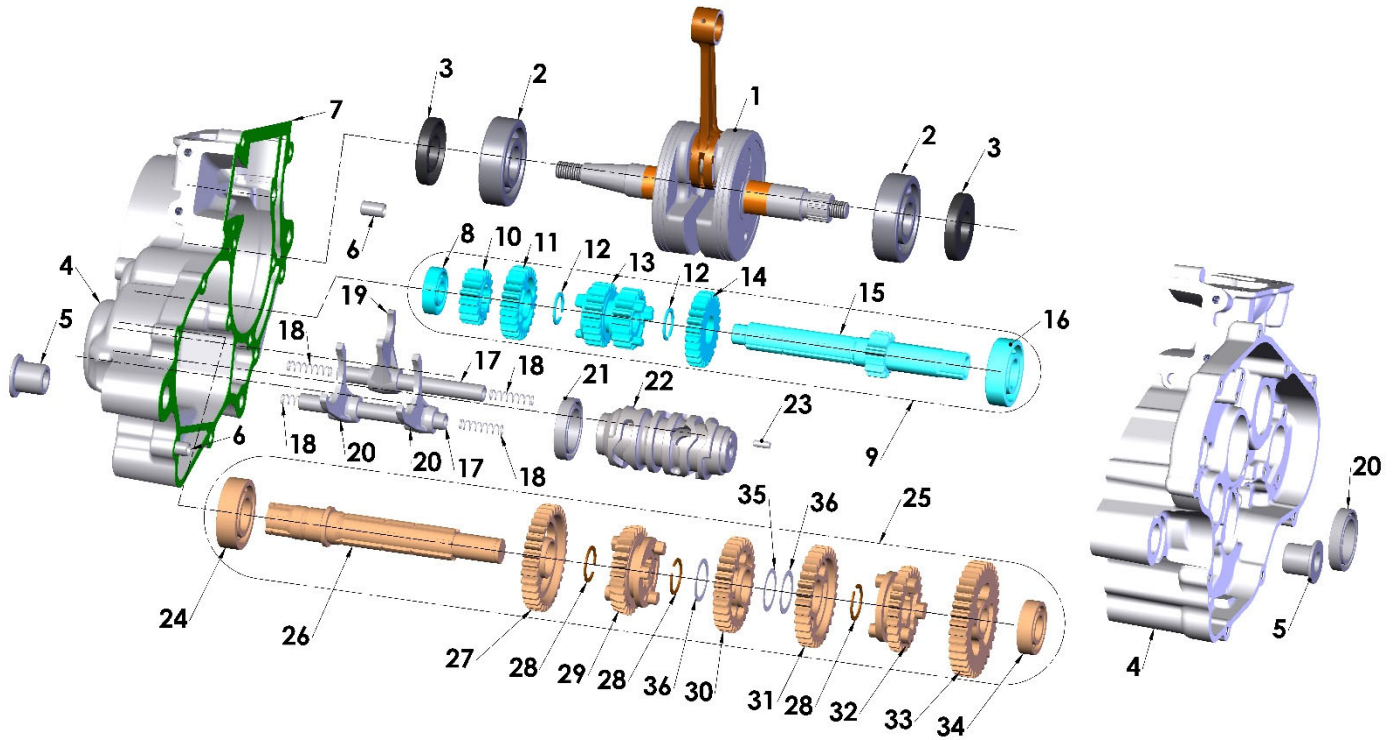

Transmission		
REF #	PART #	DESCRIPTION
1	ECC60188	CRANKSHAFT CX65
2	ECR60007	BEARING – CRANKSHAFT – IGNITION SIDE
3	ECDC0024	SEAL – CRANKSHAFT (2 REQ'D)
ACCESSORY	EKEX0001	ROD KIT
4	EKC62024	CASE SET – ENGINE W/B&S CX65
5	ECC60028	BUSHING - ENGINE / SWINGARM PIVOT CX65
6	ECMU0122	HOLLOW DOWEL - 8.4 x 14 x 7
Case Screws - Short	HCBC0630	M6X30mm SOCKET HEAD CAP SCREW (11 REQ'D)
Case Screws - Long	HCBC0635	M6X35mm SHCS (2 REQ'D) - thru the 2 hollow dowels
7	ZCC60014	GASKET – CENTER CASE
8	ECKG0031	BEARING – PRIMARY SHAFT IGNITION SIDE
9	EAC60041P	PRIMARY SHAFT SUB-ASSY
10	ECC60306M	GEAR – 2 ND PRIMARY, 16T- INVOLUTE 3 DOG ROUND
11	ECDC0005M	GEAR – 5 TH PRIMARY, 23T-3 DOG ROUND
12	ECDC0003	SNAP RING - EXTERNAL 17mm (2 REQ'D)
13	ECC60304M	GEAR – 3 RD / 4 TH PRIMARY, 18/21T-INVOLUTE 3 DOG ROUND
14	ECDC0002M	GEAR – 6 TH PRIMARY 24T – 3 DOG ROUND
15	ECC60301M	SHAFT – TRANSMISSION PRIMARY (1 ST GEAR), 13T - INVOLUTE
16	ECMU0216	BEARING – PRIMARY SHAFT CLUTCH SIDE
17	ECC60070	ROD – SHIFT FORK (2 REQ'D)
18	ECC60071	SPRING - SHIFT ROD CENTERING (4 REQ'D)
19	ECDC0048	FORK – INPUT - SHIFT
20	ECDC0049	FORK – OUTPUT - SHIFT (2 REQ'D)
21	ECDC0022	BEARING - SHIFT DRUM (2 REQ'D)
22	ECC60186	DRUM – SHIFT
23	ECDC0051	PIN – DOWEL - SHIFT DRUM TO CASSETTE
24	ECKGBR01	BEARING - OUTPUT IGNITION SIDE
25	EAC60042P	OUTPUT SHAFT SUB-ASSY
26	ECC60307M	SHAFT – TRANSMISSION OUTPUT – INVOLUTE 4 DOG SQUARE
27	ECC60114M	GEAR – 2 ND OUTPUT, 34T – 4 DOG SQUARE
28	ECDC0017	SHAP RING - EXTERNAL 18mm (3 REQ'D)
29	ECC60323M	GEAR – 5 TH , OUTPUT, 28T – INVOLUTE 4LD
30	ECC60111M	GEAR – 4 TH OUTPUT, 30T – 4 DOG SQUARE
31	ECC60110M	GEAR – 3 RD OUTPUT, 31T – 4 DOG SQUARE
32	ECC60325M	GEAR – 6 TH OUTPUT, 26T – INVOLUTE 4LD
33	ECC60116M	GEAR – 1 ST OUTPUT, 37T – 4 DOG SQUARE
34	ECDC0021	BEARING – OUTPUTSHAFT CLUTCH SIDE
35	ECC60160	SHIM – TRANSMISSION .2mm THK
36	ECC60161	SHIM – TRANSMISSION .5mm THK (2 REQ'D)
ACCESSORY	ECMU0040	SHIM – TRANSMISSION 0.030" (0.8mm) THICK
ACCESSORY	ECMU0040T	SHIM – TRANSMISSION 0.015" (0.4 mm) THIN
NOT SHOWN 1	ECMU0178	SHIM – SPROCKET – 0.5
	EAC62021	COMPLETE ENGINE

Parts – Engine – Power Valve

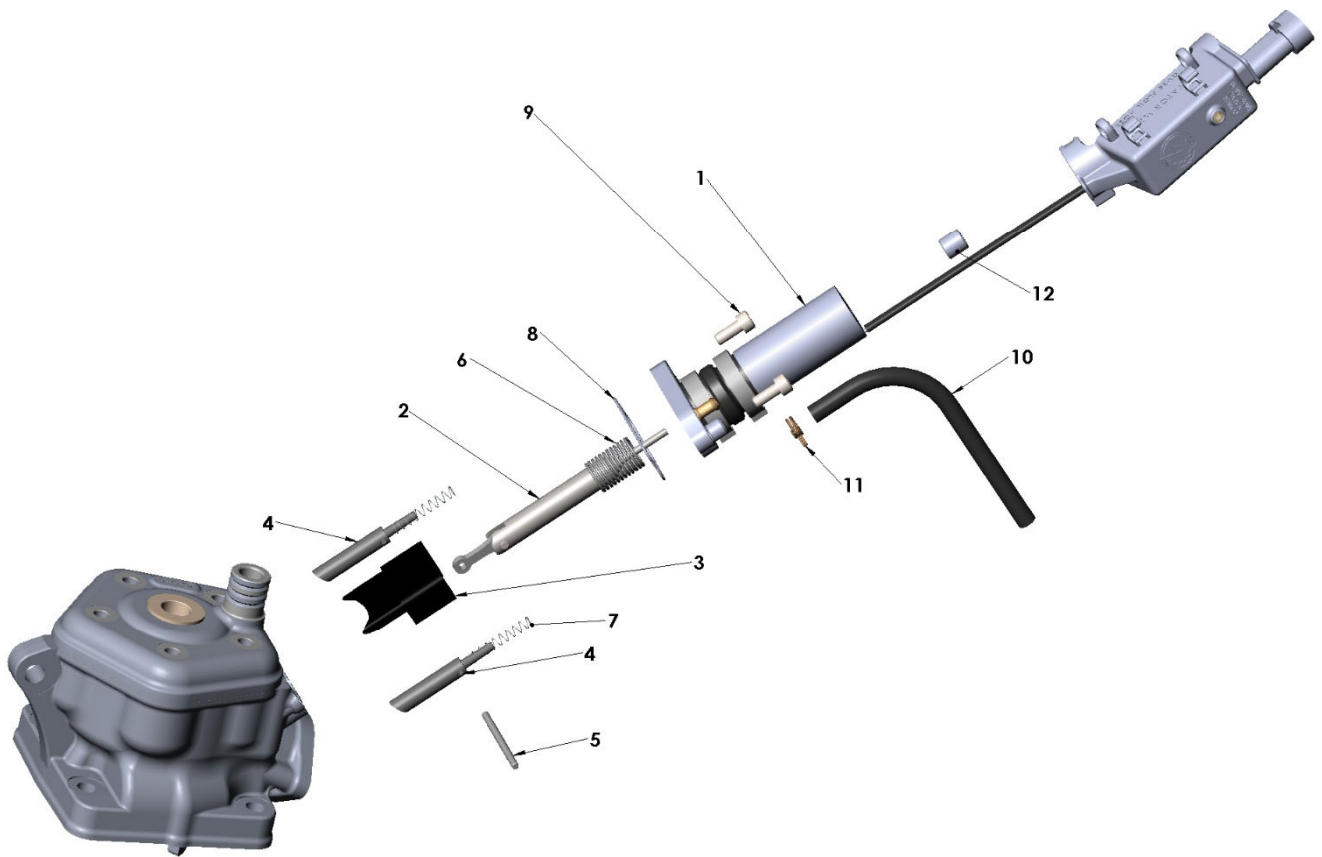

Engine – Power Valve		
REF #	PART #	DESCRIPTION
1	EAC60039	SOLENOID ASSY – WITH POWER VALVE INICATOR (PVI)
2	EAC60036	PLUNGER – WITH LINK
3	ECC60227	VALVE – MAIN
4	ECC60226	VALVE – SUB (2 REQ'D)
5	ECC60229	PIN – VALVE
6	ECC60217	SPRING – MAIN VALVE
7	ECC60233	SPRING – SUB VALVE (2 REQ'D)
8	ZCC60019	O-RING
9	HCBC0512	M5x 12 SHCS (2 REQ'D)
10	ECC60133	HOSE – VENT
11	MCMUCL04	CLAMP – VENT HOSE
12	ECC60210	ASSEMBLY KNOB

Parts – Exhaust System

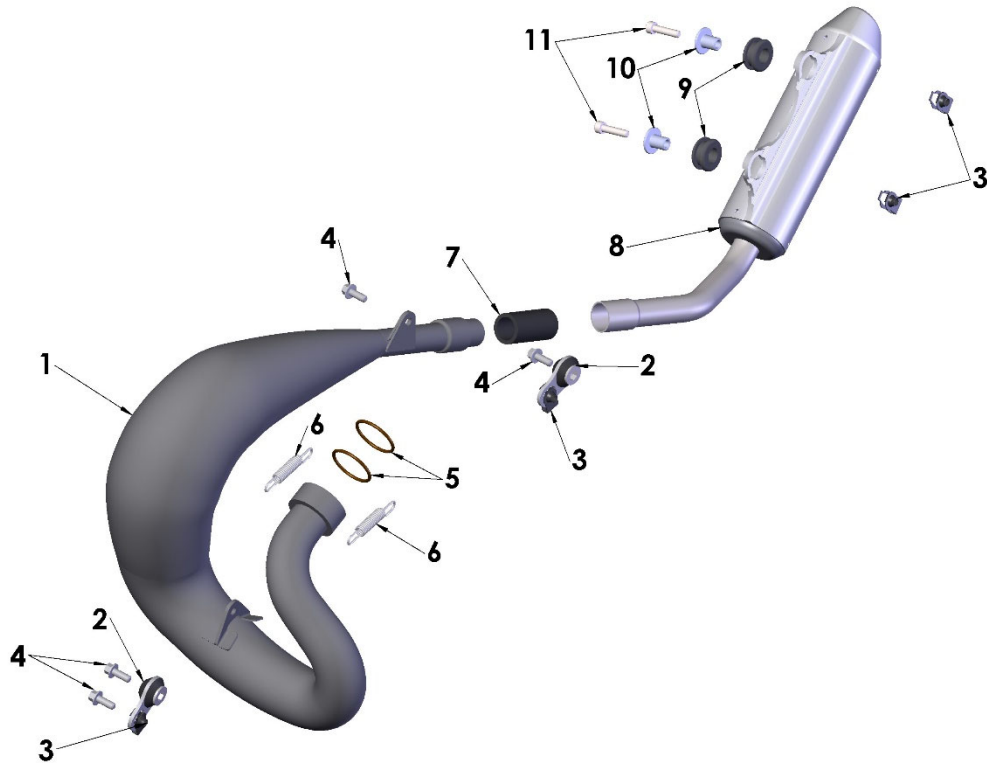

Exhaust System		
REF #	PART #	DESCRIPTION
1	XCC62017	EXPANSION CHAMBER – HGS
2	XCMU0033	ISOLATION MOUNT
3	HCHA0003	6mm CLIP NUT- PLASTIC/PIPE MNT (1 REQ'D FOR PIPE & 2 REQ'D FOR SILENCER)
4	HCBF0616	M6X16mm FLANGE HEAD BOLT (2 REQ'D)
5	ZCMOTE11	O-RING – EXHAUST (2 REQ'D)
6	XCMU0005	SPRING – PIPE – SHORT
7	XCC60020	SLEEVE – PIPE TO SILENCER
8	XAC62022	SILENCER – COBRA
9	MCMUGR03	GROMMET FOR RADIATOR (2 REQ'D)
10	XCMU0051	SPACER TOP HAT (2 REQ'D)
11	HCBC0625	M6x25mm SHCS
ACCESSORY	XCMU0053	SILENCER PACKING KIT – 7"

Parts – Forks & Triple Clamps

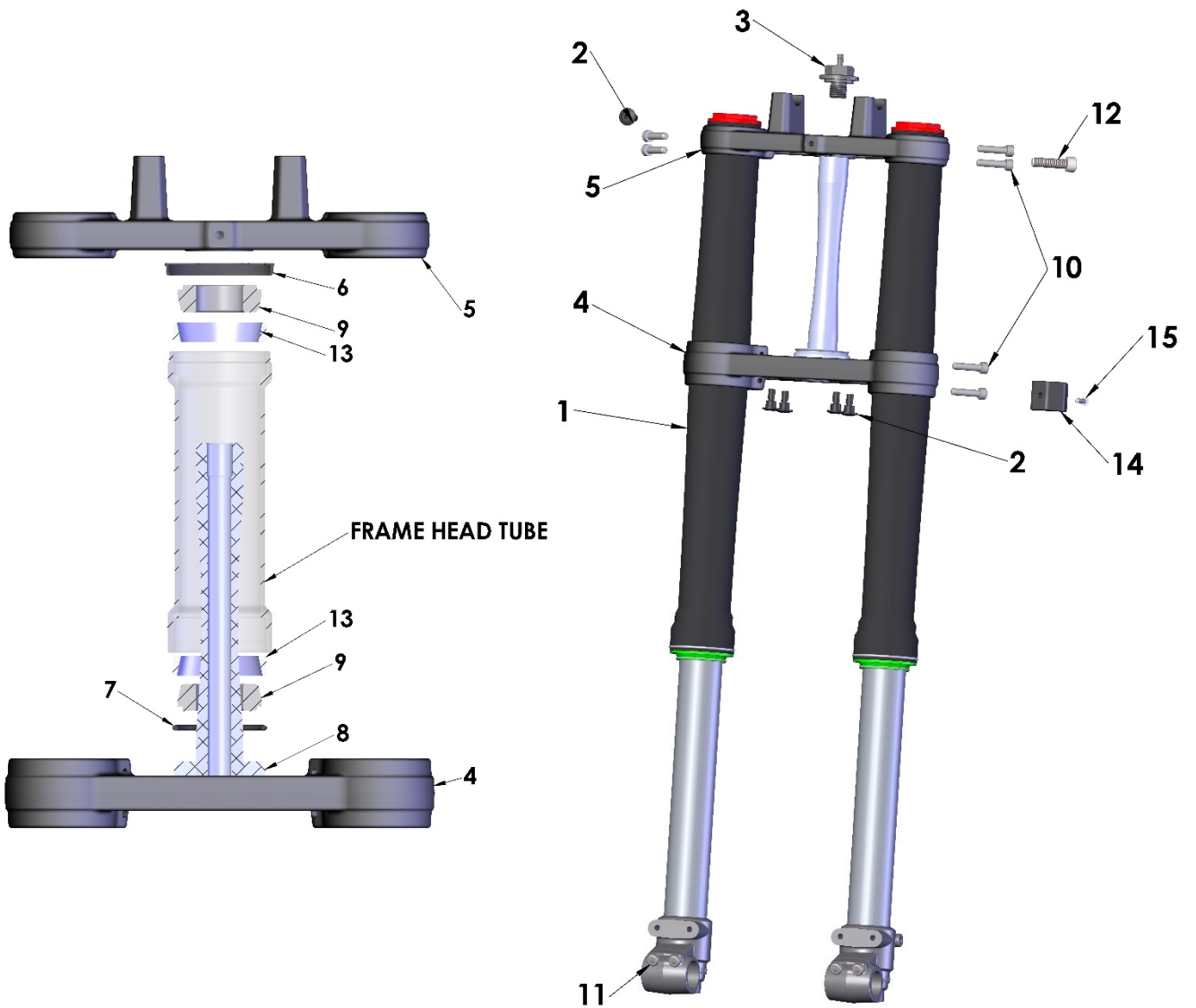

Forks & Triple Clamps		
REF #	PART #	DESCRIPTION
1	KAC62013	FORK COMPLETE, BRAKE & NON-BRAKE SIDE
2	HCSP0610BLK	BOLT - FORK GUARD - BLACK (NUMBER PLATE & FENDER)
3	FCMU0111	BOLT – STEERING STEM – w HOSE BARB
4	FAC60029BLK	TRIPLE CLAMP BOTTOM ASS'Y (CLAMP & STEERING STEM)
5	FCC60112BLK	TOP TRIPLE CLAMP-BLK
6	FCMU0079	DUST COVER (1 REQ'D)
7	FCMU0044	O-RING (1 REQ'D)
8	FCC60081	SEAL RING - ORING - BOTTOM TRIP CLAMP
9	FCMU0004	BEARING – STEERING HEAD (2 REQ'D)
10	HCBC0625	M6X25mm SOCKET HEAD CAP SCREW (8 REQ'D)
11	HCBC0601	M6X16mm SOCKET HEAD CAP SCREW (4 REQ'D) AXLE
12	HCBC0806	M8X30mm SHCS – STEERING STEM PINCH BOLT
13	FCMU0011	RACE – STEERING HEAD BEARINGS
14	FCMU0175MP	STEERING STOP (2REQ'D)
15	HCBB1416	M4x16 BUTTON HEAD (2REQ'D)
ACCESSORY	FKMU0008	KIT – STEERING STEM BEARINGS, RACES AND SEALS-2019

Parts – Fork – Leg Assembly – Brake Side

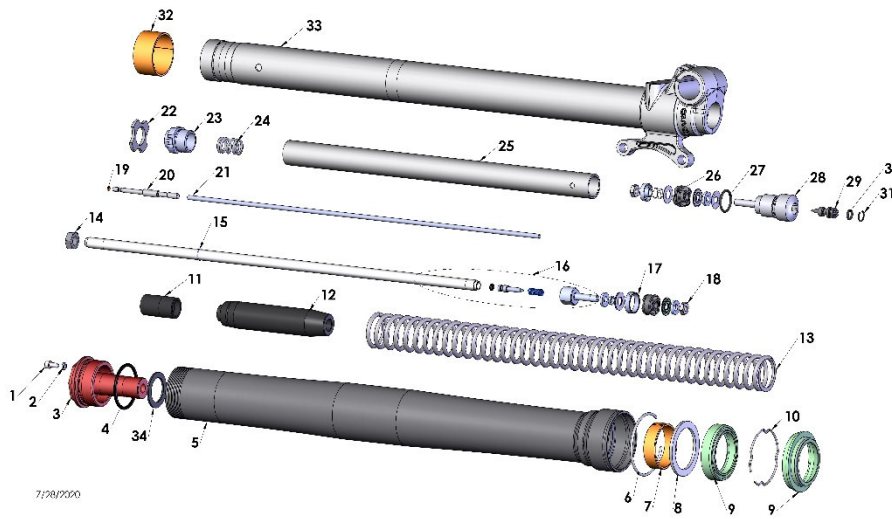

7/28/2006

Fork – Leg Assembly – Brake Side		
REF #	PART #	DESCRIPTION
1	HCBC0408	M4X8mm SOCKET HEAD CAP SCREW (BLEED SCREW)
2	ZCKG0001	GASKET BLEED SCREW
3	KCC60044L	FORK CAP
4	ZCC60011	O-RING FORK CAP
5	KCC60037	FORK OUTER TUBE
6	KCC60043	FORK OUTER WEAR RING CLIP
7	KCC60041	FORK GUIDE RING BOTTOM
8	KCC60047	FORK SEAL SPACER
9	KCC60039	FORK SEAL & SWIPER KIT - 37mm - CX65
10	KCC60066	FORK SEAL RETAINER RING CLIP
11	KCC60067	FORK BUMPER
12	KCC60064	FORK SPRING GUIDE
13	KCC63726	FORK SPRING .26 KG/MM (SINGLE)
13	KCC63724	FORK SPRING .24 KG/MM (SINGLE)
13	KCC63728	FORK SPRING .28 KG/MM (SINGLE)
14	HCNJ3824	3/8-24 JAM NUT CLASS 8
15	KCC60068	FORK SPRING GUIDE RETAINER RING CLIP
16	KAC60003	FORK DAMPER ROD ASSEMBLY
17	KCCS0018	FORK MID VALVE SEAL
18	HCNJ0601	M6 JAM NUT
19	BCKG0033	O-RING 2mm ID
20	KCC60052	FORK ADJUSTMENT SCREW TOP
21	KCC60049	FORK REBOUND ADJUSTMENT SCREW PIN
22	KCC60042	FORK SPRING PERCH
23	KCMU0013	FORK CARTRIDGE CAP W BUSHING
24	KCKG0050	FORK TOP OUT SPRING
25	KCKG0019	FORK CARTRIDGE TUBE
26	KCMU0021	O-RING FORK BASE VALVE PISTON
27	ZCKGB017	O-RING FORK BOTTOM PLUG
28	KCC60069	FORK BOTTOM PLUG
29	KCC60048	FORK ADJUSTMENT SCREW BOTTOM
30	ZCMUOR03	O-RING
31	KCC60065	FORK ADJUSTMENT SCREW BOTTOM RING CLIP
32	KCC60036	FORK GUIDE RING TOP
33	KAC60001	FORK LOWER BRAKE SIDE (NOT SOLD SEPARATELY)
34	KCC60053	FORK SPRING PAD 37MM

Parts – Fork – Leg Assembly – Non-Brake Side

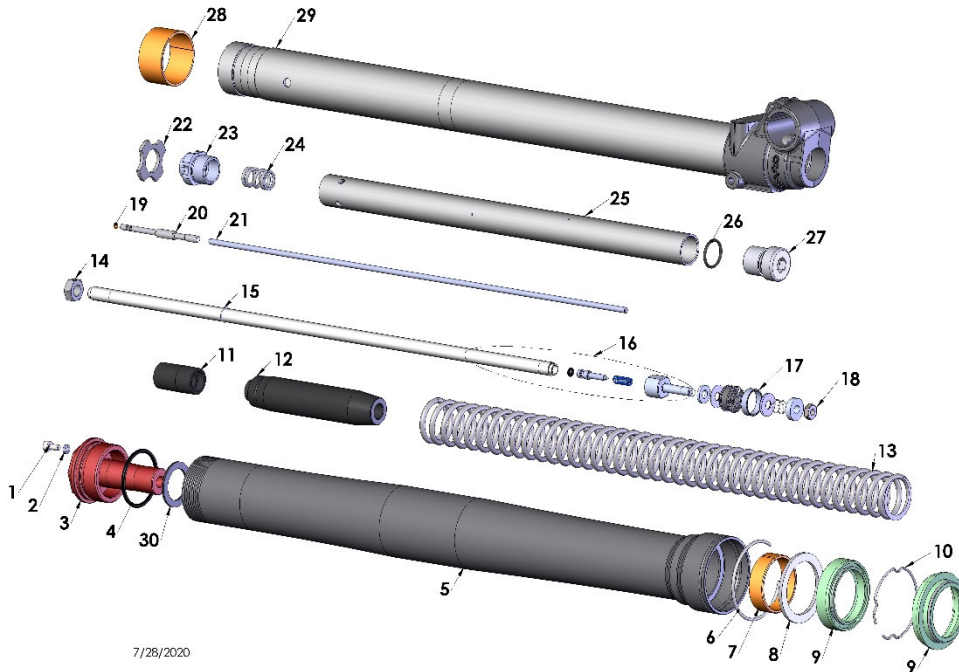

Fork – Leg Assembly – Non-Brake Side		
REF #	PART #	DESCRIPTION
1	HCBC0408	M4X8mm SOCKET HEAD CAP SCREW (BLEED SCREW)
2	ZCKG0001	GASKET BLEED SCREW
3	KCC60044R	FORK CAP
4	ZCC60011	O-RING FORK CAP
5	KCC60037	FORK OUTER TUBE
6	KCC60043	FORK OUTER WEAR RING CLIP
7	KCC60041	FORK GUIDE RING BOTTOM
8	KCC60047	FORK SEAL SPACER
9	KCC60039	FORK SEAL & SWIPER KIT – 37mm - CX65
10	KCC60066	FORK SEAL RETAINER RING CLIP
11	KCC60067	FORK BUMPER
12	KCC60064	FORK SPRING GUIDE
13	KCC63726	FORK SPRING .26 KG/MM (SINGLE)
13	KCC63724	FORK SPRING .24 KG/MM (SINGLE)
13	KCC63728	FORK SPRING .28 KG/MM (SINGLE)
14	HCNJ3824	3/8-24 JAM NUT CLASS 8
15	KCC60068	FORK SPRING GUIDE RETAINER RING CLIP
16	KAC60003	FORK DAMPER ROD ASSEMBLY
17	KCCS0018	FORK MID VALVE SEAL
18	HCNJ0006	M6 JAM NUT
19	BCKG0033	O-RING 2mm ID
20	KCC60052	FORK ADJUSTMENT SCREW TOP
21	KCC60049	FORK REBOUND ADJUSTMENT SCREW PIN
22	KCC60042	FORK SPRING PERCH
23	KCMU0013	FORK CARTRIDGE CAP W BUSHING
24	KCKG0050	FORK TOP OUT SPRING
25	KCC60056	FORK CARTRIDGE TUBE – SMART
26	ZCKGB017	O-RING FORK BOTTOM PLUG
27	KCC60057	FORK BOTTOM PLUG – SHORT
28	KCC60036	FORK GUIDE RING TOP
29	KAC60002	FORK LOWER NON-BRAKE SIDE (NOT SOLD SEPARATELY)
30	KCC60053	FORK SPRING PAD 37MM

Parts – Frame

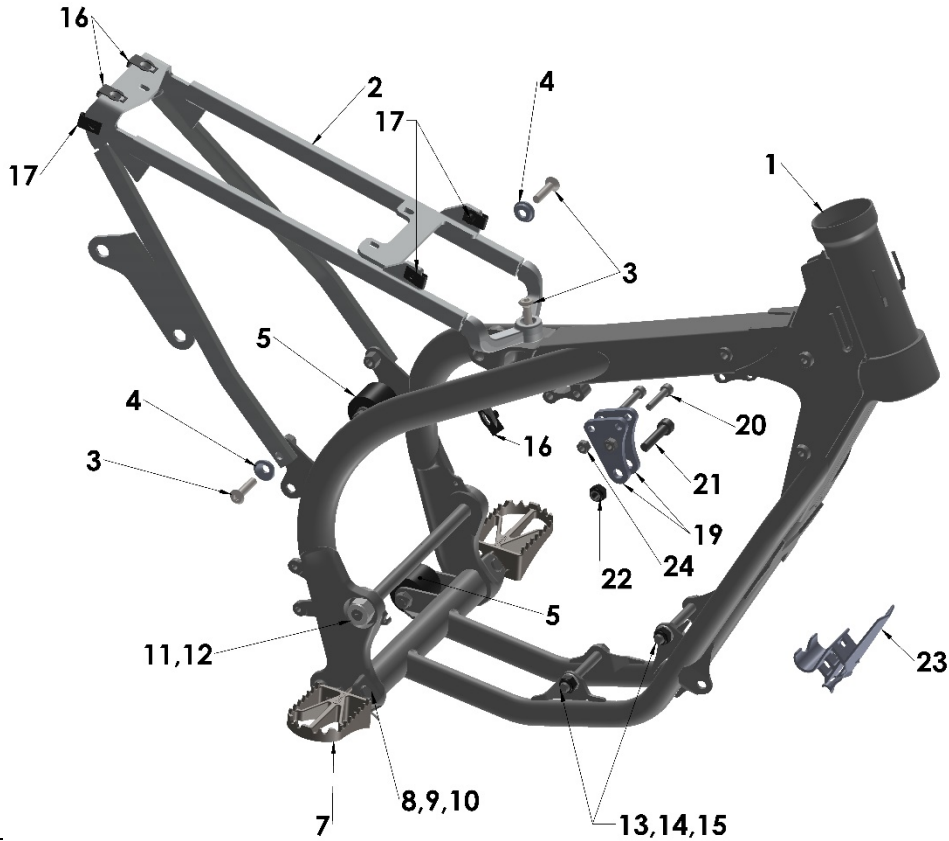

Frame

REF #	PART #	DESCRIPTION
1	FAC62024	FRAME WELDED ASSEMBLY - 2022
2	FAC60027	SUBFRAME CX65 - 2022
3	HCSP0701	M7 SPROCKET BOLT – SUB FRAME MOUNT (3 REQ'D)
4	FCMU0109	COMPRESSION LIMITER – SIDE NUMBER PLATE
5	FCC60020	CHAIN ROLLER WITH BOLT, BEARINGS & SEALS
6	HCSP0610	FORK GUARD BOLT- LOWER CHAIN SLIDE HARDWARE
7	TCMU0139	FOOTPEG SET ULTRA WIDE CX65 WITH SPRINGS
8	TCC60012	SPRING – FOOTPEG - ULTRA WIDE 07 (2 REQ'D)
9	FCMU0031	CLEVIS PIN - FOOTPEG
10	HCCP0008	COTTER PIN 1/8 X 3/4
11	GCC60020	SWINGARM PIVOT BOLT - TI
12	HCNL1201	12MM LOCKNUT
13	HCBH0865	8X65MM HEX HEAD – FRONT ENGINE MOUNTS (2 REQ'D)
14	HCWF0801	8MM FLAT WASHER – FRONT ENGINE MOUNTS (4 REQ'D)
15	HCNL0801	8MM LOCKNUT – FRONT ENGINE MOUNTS (2 REQ'D)
16	HCHA0003	6mm CLIP NUT
17	HCCN0001	5mm CLIP NUT (4 REQ'D)
18		
19	FCC60117	BRACKET – HEAD STAY (2 REQ'D)
20	HCBC0630	M6x 30mm SHCS (2 REQ'D)
21	HCBF0835	M8x 35mm FLANGE HEAD
22	HCNL0801	M8 NYLOCK NUT
23	TCC60041	GUARD – POWER VALVE
24	HCNL0601	M6 NYLOCK NUT (2 REQ'D)
NOT SHOWN	MCMUZT28	ZIP TIE – REUSABLE

Parts – Front Wheel

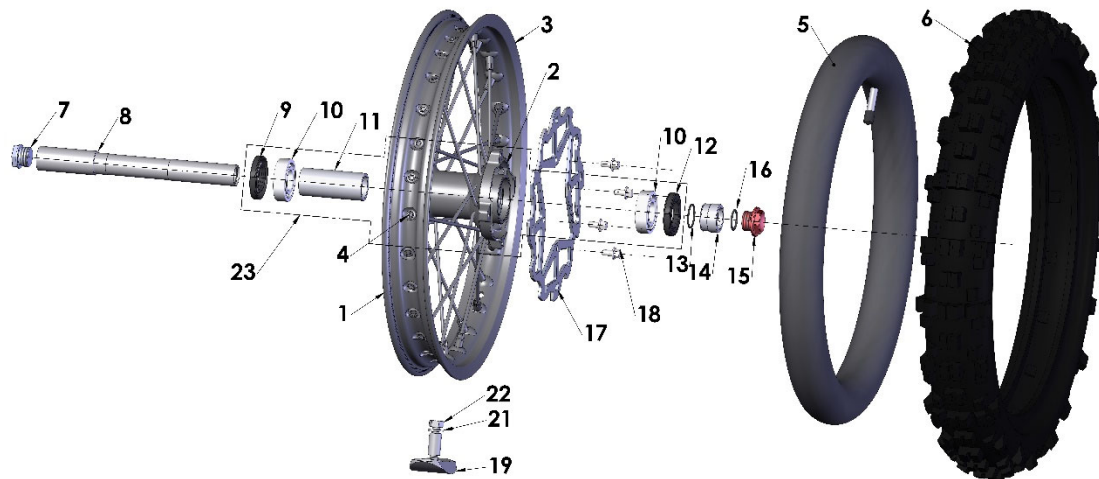

Front Wheel		
REF#	PART #	DESCRIPTION
1	WAC6F018	WHEEL 14" FRONT WITH BEARINGS & SEALS (NO TIRE, OR TUBE), BLACK
2	WCC60122	HUB FOR CX65 – FRONT
3	WCMU1418BLK	14" RIM, BLACK
4	WKC6F023	SPOKE W NIPPLE-FRONT WHEEL-65 (28 REQ'D)
5	WCDCTU14	TUBE – 60/100-14 FRONT
6	WCC6F014D32	TIRE - FRONT- 60/100-14 - DUNLOP MX3S
7	WCC60024	PLUG – AXLE - NON BRAKE SIDE (SMALER ONE)
8	WCC60021	AXLE FRONT STEEL
9	WCC60029	SEAL BEARING NON-BRAKE SIDE FRONT HUB
10	WCC60027	BEARING, WHEEL-SEALED (2 REQ'D)
11	WCC60030	SPACER WHEEL BEARING FRONT
12	WCC60026	SEAL BEARING BRAKE SIDE FRONT HUB
13	ZCMUOR22	O’RING – SPACER - FRONT AXLE
14	WCC60025	WHEEL SPACER FRONT LEFT
15	WCC60023	PLUG – AXLE - BRAKE SIDE (LARGER ONE)
16	ZCKGB017	O’RING – AXLE CAP
17	BCC60100	BRAKE ROTOR - FRONT
18	HCBF1612	M6X12mm FLANGE HEAD – LOW PROFILE (4 REQ'D)
19	WCMU0019	RIM LOCK – 1.4/1.6
21	HCWF0801	8mm FLAT WASHER
22	HCNS0801	M8 NUT
23	WAC6F118	FRONT HUB ASSEMBLY WITH BEARINGS, SEALS, AND SPACER
TOOL	MCMUTL17	WRENCH – SPOKE

Parts – Front Brakes – Master Cylinder

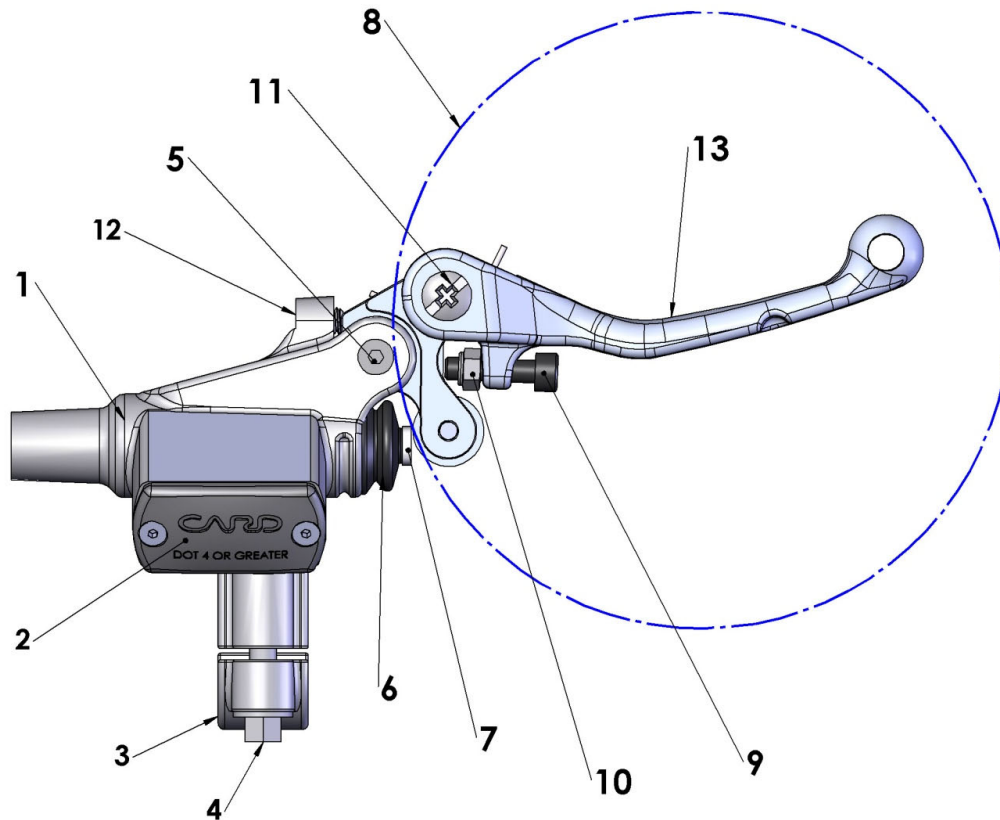

Front Brakes		
REF#	PART #	DESCRIPTION
	BAC60017	ASSY – FRONT BRAKE SYSTEM COMPLETE - FRONT CX65
1	BAC60016	ASSEMBLY - BRAKE MASTER CYLINDER (M/C) W LEVER ASSY
2	BKC60008	CAP & BLADDER KIT ZL150 (CAP, BLADDER & (2) M3-0.5 X 6mm LONG PHILLIPS SCREW)
3	BCC60058	CLAMP – M/C ZL150
4	HCBF1625	M6-1.0 X 25mm LONG FLANGE HEAD BOLT
5	BCMU0060	PIVOT BOLT – PIVOT BLOCK TO MASTER CYLINDER HOUSING (BOLT & CLIP)
6	BCC60017	BOOT – PISTON END COVER
7	BKC60015	REBUILD KIT – MASTER CYLINDER ZL150 (PISTON, SEALS, SPRING, CLIP & RETAINING WASHER)
8	CKC60004	LEVER ASSEMBLY - CLUTCH / BRAKE - BRAKEAWAY ROLLER (LEVER ON PIVOT BLOCK W ROLLER & ADJUSTMENT SCREW W NUT)
9	HCBC0502	M5 X 20 SOCKET HEAD CAP SCREW - LEVER POSITION ADJUSTMENT
10	HCNL0501	5MM LOCKNUT
11	CKC60005	PIVOT BOLT KIT – LEVER TO PIVOT BLOCK (MALE AND FEMALE BOLTS)
12	HCSS0610	SET SCREW – PRESET
13	CCC60015	LEVER ONLY – CLUTCH OR BRAKE
ACCESSORY	BKC60004	LEVER ASSEMBLY - SHORTY
NOT SHOWN	BCMU0116	BOOT – PIVOT COVER
NOT SHOWN	CCC60026	SPRING – LEVER RETURN
NOT SHOWN	CCC60025	SPACER – SPRING CENTERING
NOT SHOWN	BCC60054B	LINE – FRONT CX65 ZL150

Parts – Front Brakes – Caliper

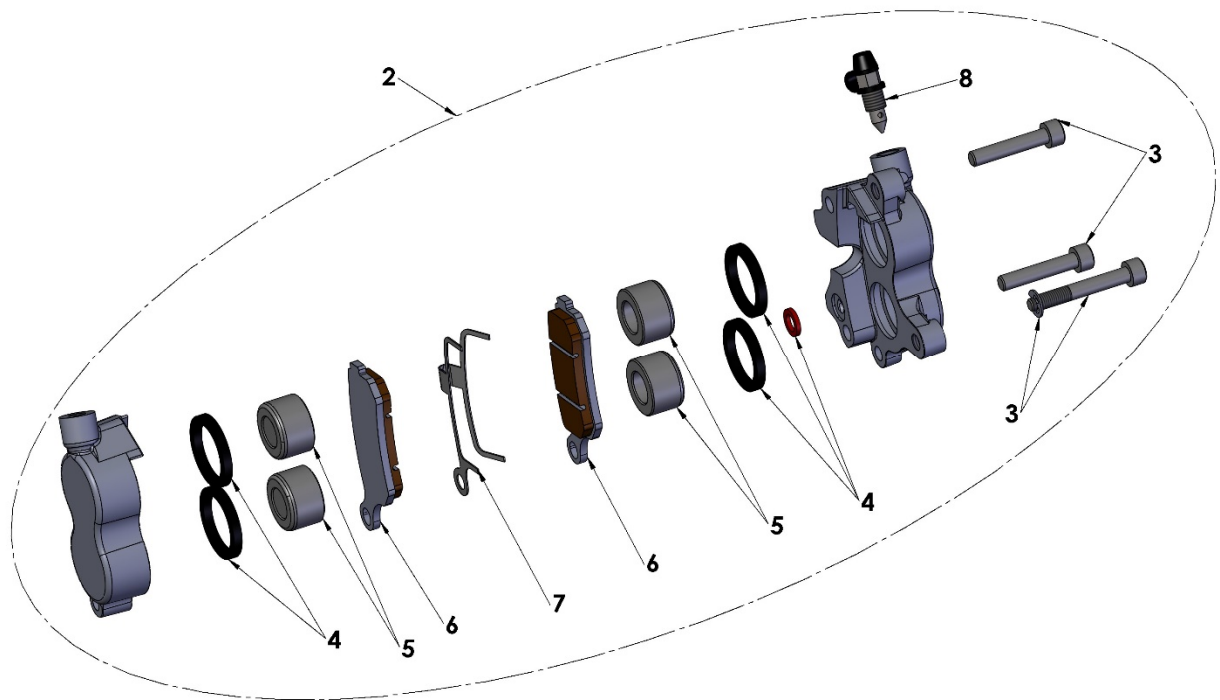

Front Brakes		
REF#	PART #	DESCRIPTION
NOT SHOWN	BAC60008	ASSY COMPLETE – FRONT CX65 (M/C-LINE-CALIPER) ZL150
2	BAC60009	CALIPER ASSY – CX65 ZL150
3	BKC60003	CALIPER FASTENER KIT ZL150
		<i>PAD PIN - ZL150</i>
		<i>CLIP - PIN ZL150</i>
		<i>2 - M6X32mm LONG ZL150</i>
4	BKC60002	SEAL KIT – CALIPER ZL150
		<i>1 - CALIPER CENTER SEAL ZL150</i>
		<i>4 - SEAL BRAKE PISTON ZL150</i>
5	BKC60017	PISTON and Seal Kit
6	BCC60050	PAD SET ZL150
7	BCC60051	SPRING – PAD ZL150
8	BCC60033	BLEED SCREW & CAP KIT
NOT SHOWN	BCC60054B	LINE FRONT CX65 ZL150

Parts – Plastic Bodywork & Seat

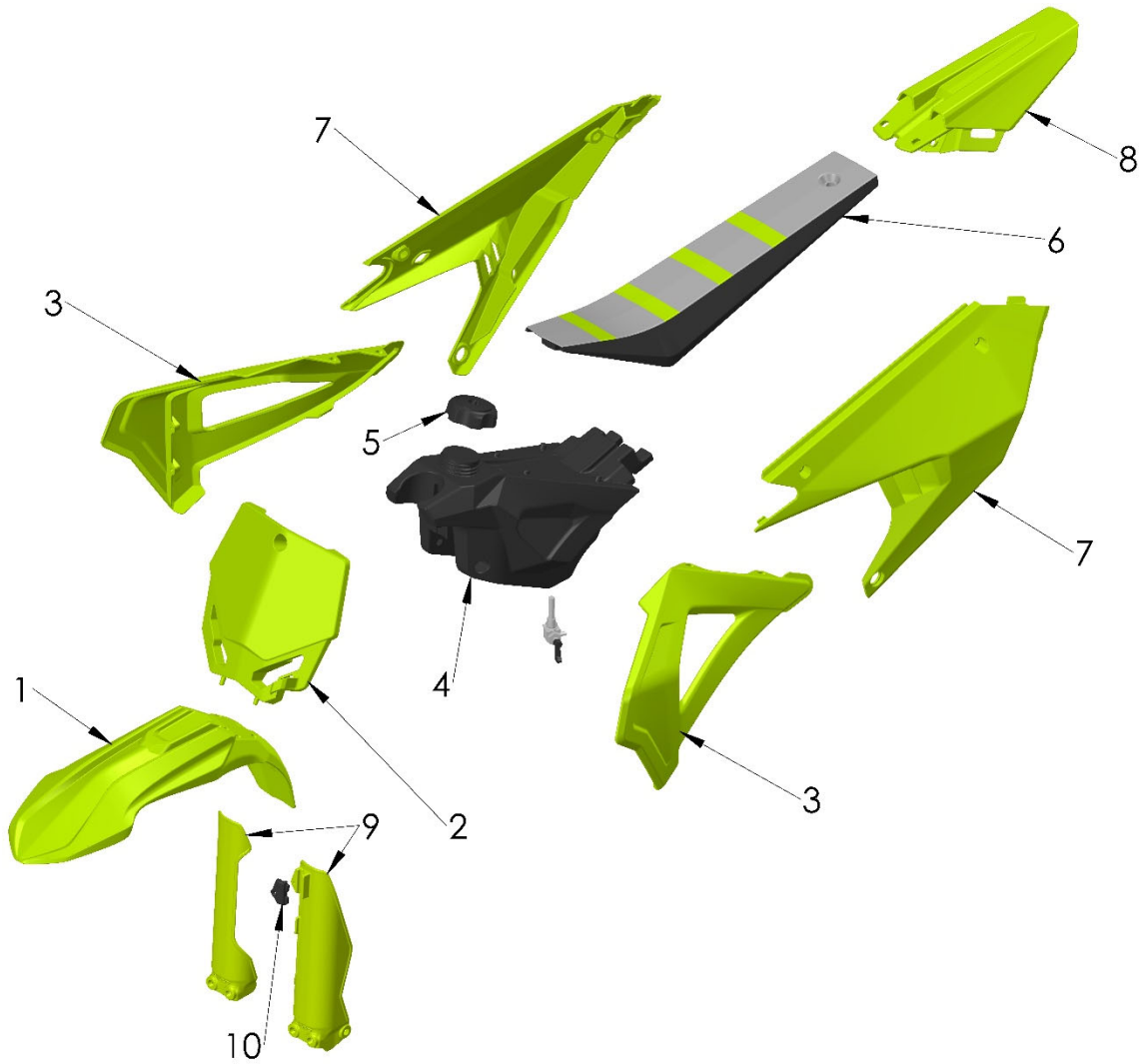

Plastic Bodywork & Seat		
REF #	PART #	DESCRIPTION
1	TCCS0009FXX	FRONT FENDER – MEGA FLO YELLOW
1	TCCS0009BLK	FRONT FENDER – BLACK
1	TCCS0009WHT	FRONT FENDER – WHITE
1A	HCSP0610BLK	FORK GUARD BOLT - BLACK(4 REQ'D)
2	TCMU0041FXX	NUMBER PLATE FRONT - WHITE - STANDARD
2	TCMU0041BLK	NUMBER PLATE FRONT - BLACK
2	TCMU0041FXX	NUMBER PLATE FRONT – MEGA FLOW YELLOW
2A	HCSP0610BLK	FORK GUARD BOLT - BLACK
3	TCMU0043BLK	SHROUD SET – BLK
3	TCMU0043FXX	SHROUD SET – MEGA FLO YELLOW
3	TCMU0043WHT	SHROUD SET – WHITE
3A	HCSP0004	PLASCREW – SHROUD TO TANK (4 REQ'D)
4	TCMU0048	FUEL TANK – BLACK - (NO PETCOCK OR CAP)
4A	HCFH0675	M6x75mm FLAT HEAD SCREW
4B	TCMU0047	SPACER – FRONT TANK MOUNTING
4C	TCMU0017	SQUARE NUT – FRONT TANK MOUNT
4D	TCC60029	SPACER – SEAT MOUNT
4E	HCFH0620	M6X20mm FLAT HEAD – FRONT SEAT MOUNT
4F	TCMU0151	PETCOCK
5	TCHA0002	CAP – FUEL TANK
5A	TCHA0003	HOSE – FUEL CAP
6	TAC62025	SEAT – CX65
6A	TCC60046	SEAT COVER REPLACEMENT
6B	HCFH0650	M6x50mm FLAT HEAD SCREW – SEAT HOLDING
6C	TCMU0046	SPECIAL WASHER – SEAT HOLDING
7	TCC60039FXX	SIDE NUMBER PLATE – PAIR – WHITE – STANDARD
7	TCC60039BLK	SIDE NUMBER PLATE – PAIR – BLACK
7	TCC60039FXX	SIDE NUMBER PLATE – PAIR – MEGA FLO YELLOW
7A	HCBC0502	M5X20mm SOCKET HEAD CAP SCREW (2 REQ'D)
7B	HCSP0701	M6X30mm FLANGE HEAD BOLT – SILENCER (1 REQ'D)
7C	TCC60017	BODY PANEL WASHER 5mm (3 REQ'D)
7D	FCMU0109	COMPRESSON LIMITER – LOWER SUBFRAME MOUNT
8	TCMU0055FXX	FENDER – REAR – MEGA FLO YELLOW
8	TCMU0055BLK	FENDER – REAR – BLACK - STANDARD
8	TCMU0055WHT	FENDER – REAR – WHITE
8A	HCSP0610BLK	FORK GUARD BOLT (4 REQ'D)
8D	HCHA0003	CLIP NUT – M6
9	KCC60071FXX	FORK GUARDS – PAIR (3 BOLT STYLE)
9A	HCSP0610BLK	BOLT - FORK GUARD - 6MM ALUMINUM - BLACK
10	KCMU0036	CLAMP – BRAKE LINE
10A	HCSP0004	PLASTIC SCREW
	TCC62025	GRAPHIC KIT
	TKC62025	BODYWORK KIT – CX65 – FXX PLASTIC W WHITE # PLATES
	TKC62025FXX	BODYWORK KIT – CX65 – MEGA FLO PLASTIC
	TKC62025BLK	BODYWORK KIT – CX65– PLASTIC BLACK
	TKC62025WHT	BODYWORK KIT – CX65 – PLASTIC WHITE

Parts – Rear Brake

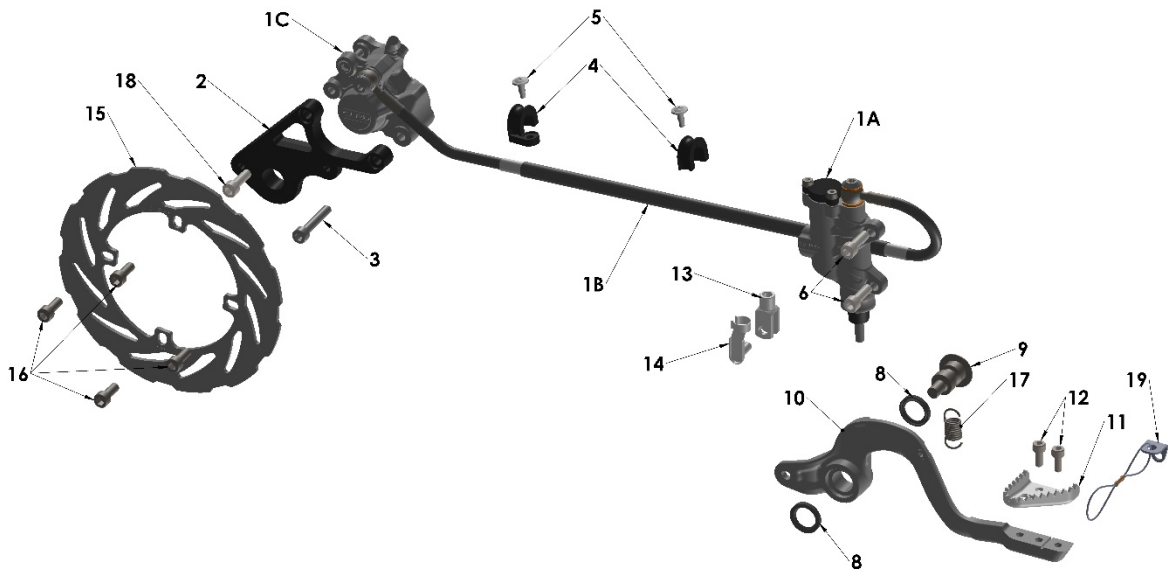

Rear Brake System		
REF #	PART #	DESCRIPTION
1	BAC60019	BRAKE ASSEMBLY REAR (MASTER CYLINDER, LINE AND CALIPER)
1A	BAMU0014	MASTER CYLINDER CX65 11MM – CAPTURED CLEVIS
1B	BCC60104B	LINE REAR CX65
1C	BAMU0010	CALIPER CX65
2	BCC60093	BRACKET – CALIPER MOUNTING
3	HCBC0635	M6 x 35 SOCKET HEAD CAP SCREW
4	HCCC0005	HOSE GUIDE (2 REQUIRED)
5	HCPP0832	#8X1/2 SELF TAPING SCREW (2 REQUIRED)
6	HCBC0620	M6X20mm SHCS (2REQ'D)
7	BCM0022	RUBBER CAP – BOTTOM OF MASTER CYLINDER
8	BCM00501	SEAL-BRAKE PEDAL (2 REQUIRED)
9	BCM0027	PIVOT BOLT – ALUMINUM BRAKE PEDAL
10	BCM0069	BRAKE PEDAL WITH TOE PIECE
11	BCM0023T	TOE PIECE – BRAKE PEDAL
12	HCBC0512	M5X 12mm SOCKET HEAD CAP SCREW
13	BCM0015A	BRAKE CLEVIS
14	BCM0015B	RETAINER - BRAKE CLEVIS
	HCBC0625	M6x 25mm SHCS
15	BCC60004	ROTOR REAR
16	HCBC0601	M6X16mm SOCKET HEAD CAP SCREW (4 REQUIRED)
17	BCMUSP03	SPRING – REAR BRAKE PEDAL
18	HCBC0620	M6X20mm SOCKET HEAD CAP SCREW
19	BAC60020	BRAKE SNAKE
ACCESSORY	BKC60016	PAD SET CX65 SINTERED METAL W BOLT AND CLIP
ACCESSORY	BKMU0003	BLEED KIT (MULTIPLE SYRINGES, FITTINGS & HOSE)
ACCESSORY	BCM0038	SPRING - BRAKE PAD RETURN
ACCESSORY	BKMU0006	PISTON & SEAL KIT – CARD - STAINLESS
ACCESSORY	BKMU0008	BLEED SCREW KIT – CARD
ACCESSORY	BCC60034	CAP ONLY BLEED SCREW CX65
ACCESSORY	BKMU0013	CAP & DIAPHRAGM KIT – MASTER CYLINDER
ACCESSORY	BKMU0014	REBUILD KIT – MASTER CYLINDER – CARD CAPTURED
ACCESSORY	BKMU0007	BANJO BOLT AND WASHER KIT – CARD
ACCESSORY	BCC60045	SHARK FIN
TOOL	BKMU0003	BLEEDING KIT – FORMULA & CARD

Parts – Rear Wheel

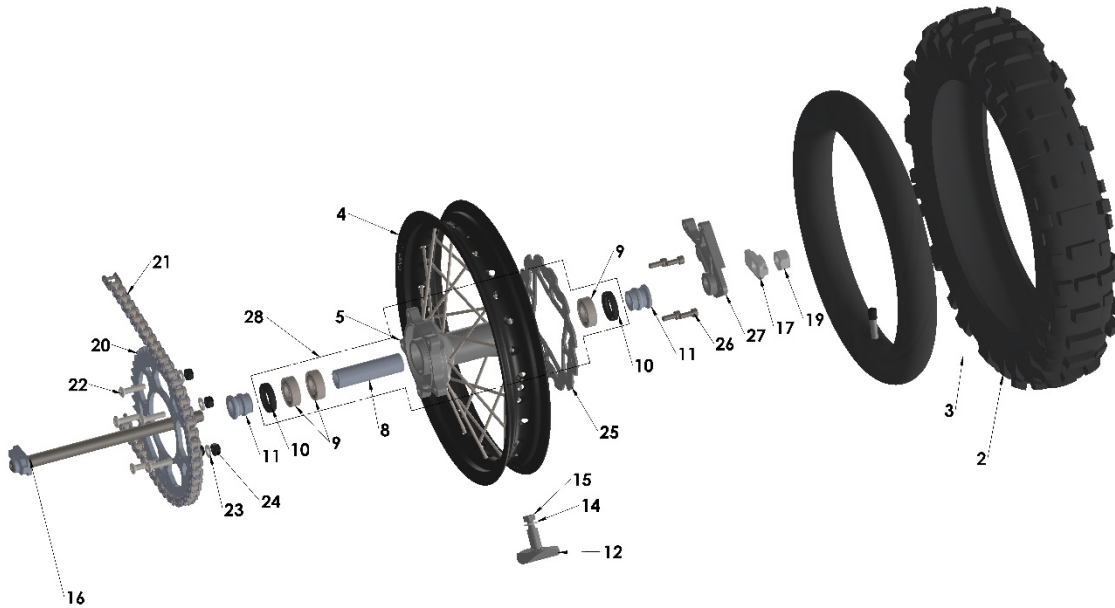

Rear Wheel		
REF #	PART #	DESCRIPTION
1	WAC6R018	WHEEL 12" REAR W BEARINGS, BLACK (NO TIRE, TUBE, ROTOR OR SPROCKET)
2	WCC6R012D32	TIRE - REAR - 80/100-12 - DUNLOP MX3S
3	WCDCTU12	TUBE – 275-80/100-12 REAR
4	WCMU1218BLK	12" RIM, BLACK
5	WAC6R118	HUB REAR SEALED - BLACK
6	WKC6R023	SPOKE & NIPPLE KIT – REAR WHEEL-65 (28 REQ'D)
8	WCC60037	SPACER – REAR WHEEL BEARING
9	WCMU0120	BEARING, WHEEL
10	WCC60035	SEAL – REAR HUB
11	WCC60036	SPACER – L&R REAR WHEEL
12	WCMU0019	RIM LOCK – 1.4/1.6
14	HCWF0801	8mm FLAT WASHER
15	HCNS0801	8mm NUT
16	WCC60010	AXLE REAR CX65 - TI
17	GCC60010	CHAIN ADJUST BLOCK OFFSET
19	WCC60011	NUT – ALUMINUM ACORN
20	PCC618xx	SPROCKET – xx denotes number of teeth (37-53)
21	PCMU0116	CHAIN 420H 116 LINK CX65 14/48
22	HCSP0701	7mm SPROCKET BOLT (5 REQ'D)
23	HCWF0701	7mm FLAT WASHER (5 REQ'D)
24	HCNL0701	7mm LOCK NUT (5 REQ'D)
25	BCC60004	BRAKE ROTOR REAR
26	HCBC0601	M6X16mm SHCS (4 REQ'D)
27	BCC60093	BRACKET – CALIPER MOUNTING
28	WAC6R118	REAR HUB ASSEMBLY WITH BEARINGS, SEALS, AND SPACER
TOOL	MCMUTL17	WRENCH – SPOKE

Parts – Shock External

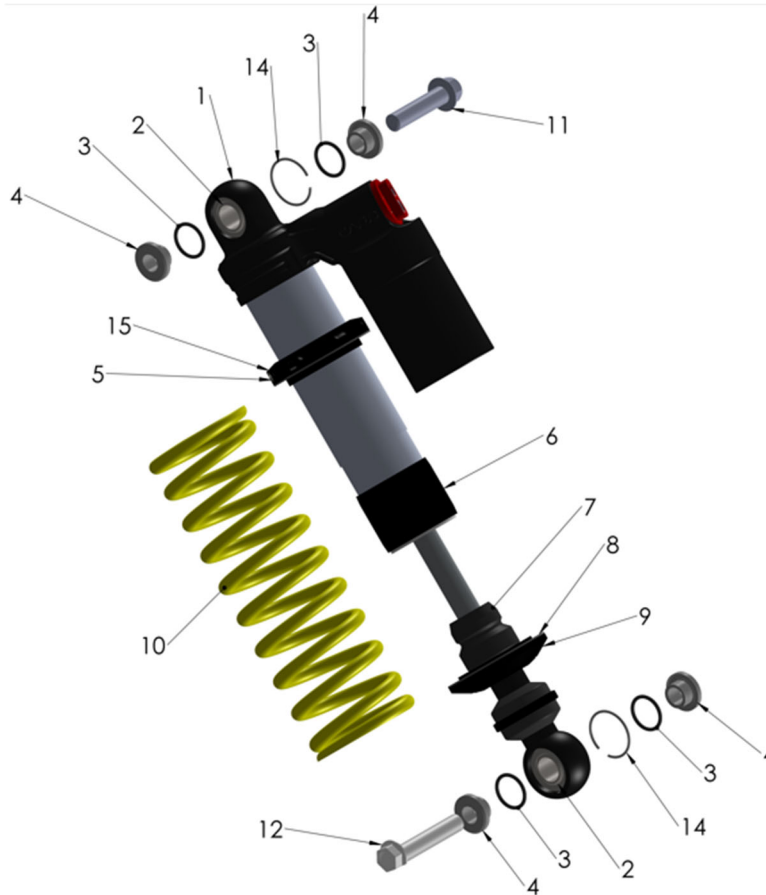

Shock		
REF #	PART #	DESCRIPTION
1	SAC62024	SHOCK ABSORBER – CX65
2	SCMU0043	SHOCK – BEARING SPHERICAL SHOCK MOUNT–CARD (2 REQ'D)
3	SCMU0039	O-RING – SHOCK - BUSHING – CARD (4 REQ'D)
4	SCMU0042	SHOCK – MOUNT BUSHING – CARD (4 REQ'D)
5	SCMU0058	SHOCK – WHITE NYLON TIP SETSCREW M6-1.0 - CARD
6	SCMU0056	SHOCK – SLEEVE BLACK - CARD
7	SCMU0100	BUMPER – TAPERED - SHOCK
8	SCMU0040	PAD – SPRING - CARD
9	SCMU0054	PERCH – SPRING - CARD
10	SCC60220P	SPRING EXTRA EXTRA LIGHT 220 LB/IN (38.5 N/mm) red
10	SCC60240P	SPRING EXTRA LIGHT 240 LB/IN (42N/mm) white
10	SCC60260PY	SPRING STANDARD 260 LB/IN (45.5 N/mm) yellow
10	SCC60280PG	SPRING HEAVY 280 LB/IN (49 N/mm) black
10	SCC60300P	SPRING HEAVY 300 LB/IN (52.5 N/mm) gray & red
11	HCBF1039	M10 X 39 FLANGE HEAD BOLT
12	HCSP1055	M10 X 55 OFFSET HEAD BOLT
13	HCNL1001	10mm LOCKNUT-REGULAR
14	SCMU0330	RING -SPERICAL BEARING RETAINING -CARD SHOCKS
15	SCMU0120	PRELOAD ADJUSTER – CARD SHOCK

Parts – Shock – Internal

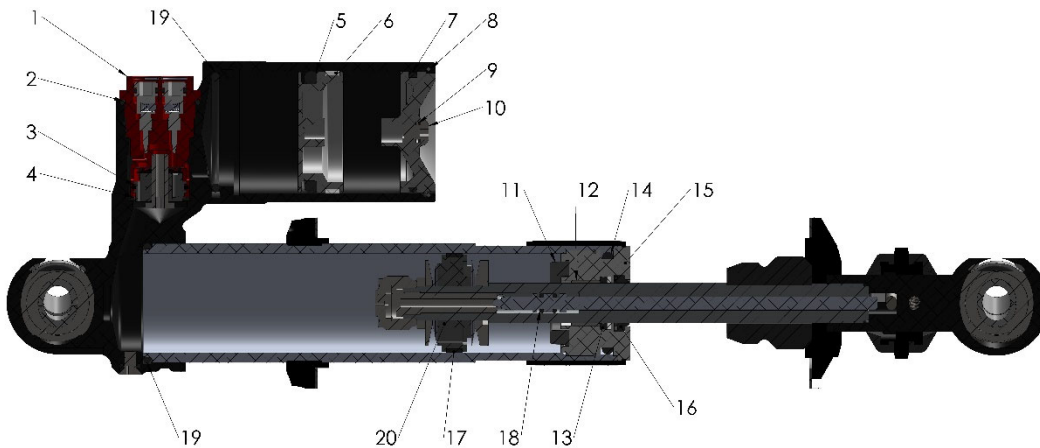

Shock		
REF #	PART #	DESCRIPTION
1	SAMU0001	COMPRESSION ADJUSTER ASSEMBLY – COMPLETE
2	ZCMUB020	O-RING – COMPRESSION ADJUSTER – OUTSIDE
3	KCMU0021	O-RING – COMPRESSION ADJUSTER – PISTON SEAL
4	ZCMUOR37	O-RING – COMPRESSION ADJUSTER – INSIDE
5	SCMU0051	O-RING – IFP
6	SCMU0052	IFP SEAL BAND
7	SCMU0033	O-RING SHOCK BASE
8	SCMU0050	RESERVOIR CAP RETAINER RING
9	SCMU0035	O-RING CHARGE CAP
10	HCBB0506	M5X6mm LONG BUTTON HEAD STAINLESS STEEL
11	SCMU0044	BUMPER – SEAL HEAD
12	SCMU0048	SHAFT BUSHING
13	SCMU0046	X-RING SEAL – SHOCK
14	SCMU0034	O-RING SEAL HEAD
15	SCMU0047	SPACER – X-RING
16	SCMU0045	DUST SEAL – SHOCK SHAFT
17	SCC60014	PISTON BAND
18	SCMU0059	O-RING REBOUND PIN
19	SCMU0033	O’RING - BODY & RESERVOIR SEAL TO BODY CAP
20	SCMU0091	PISTON - SHOCK
	SCCM0001	SEAL HEAD – WITHOUT COMPONENTS
ACCESSORY	SKMU0002	SEAL HEAD - COMPLETE
ACCESSORY	SKMU0003	REBUILD KIT – NO SEAL HEAD

Parts – Swingarm Assembly

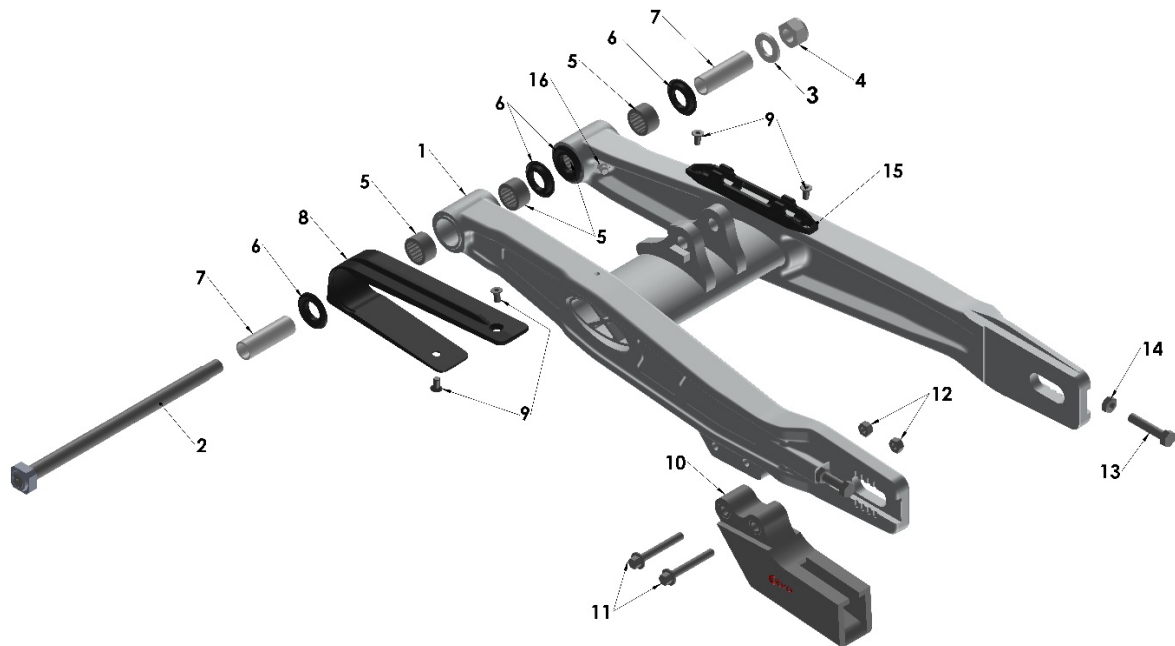

Swingarm		
REF #	PART #	DESCRIPTION
1	GAC62025	SWINGARM – CX65 2022 - CURRENT
2	GCC60020	BOLT – SWINGARM PIVOT - TI
3	HCWF1202	12mm WASHER – SWINGARM PIVOT
4	HCNL1201	M12 LOCK NUT – SWINGARM PIVOT
5	GCC60017	BEARING – SWINGARM PIVOT (4 REQ'D)
6	GCMU0047	SEAL / THRUST BEARING – SWINGARM PIVOT (4 REQ'D)
7	GCC60019	TUBE – SWINGARM PIVOT (2 REQ'D)
8	PCC60006	CHAIN SLIDER TOP FOR SWINGARM
9	HCFH0516	M5 X 16mm FLAT HEAD SCREW (2 REQ'D FOR CHAIN SLIDER)
10	PCC60004	CHAIN GUIDE (BOTTOM) CX65
11	HCBC0645	M6X45mm SOCKET HEAD CAP SCREW (2 REQ'D)
12	HCNF0602	M6 FLANGE NYLOCK NUT (2 REQ'D)
13	HCBH0701	M7X35mm HEX HEAD FULL THREAD (2 REQ'D)
14	HCNS0701	M7 NUT (2 REQ'D)
15	GCC60051	GUIDE - BRAKE HOSE - CX65 2025 -
16	GCMU0012	FITTING – GREASE (2 REQ'D)

Service

Trained technicians with precision gauging and proper assembly fixtures carefully assemble all Cobra engines to specific tolerances. If you feel you have the skills, and the appropriate tools, to perform the following service tasks please follow the instructions closely. The part numbers are listed throughout to help you when ordering parts from your local Cobra dealer.

If you don't feel comfortable with the service work, log on to www.cobramoto.com to find a Cobra dealer or Call 517-437-9100.

Engine Service

One method for determining whether the top end of your engine needs rebuilt is to perform a WOT (Wide Open Throttle) kicking compression test. Before performing the procedure please read the caution notes below.

CAUTION:

- There appears to be a wide range of variability in reading compression gauges across the country.
- The head volume of this Cobra Motorcycle is very small and so requires many kicks, around 20, before you establish the most accurate reading possible.
- Because of the geometry of the spark plug used in this Cobra Motorcycle, the adapter used with your compression tester must have a similar volume protruding into the combustion chamber to establish an accurate value.
- Length of hose on the compression tester will affect the reading. The shorter the hose length the more accurate your reading will be.

Because of these difficulties in measuring an *absolute* compression value, a useful *relative* value can be achieved by testing your bike's compression with your own particular gauge after a new top end or when the bike is new so that you know what your particular gauge reads on a 'fresh' engine. When it has dropped to 90% of its original value the engine will be down on power and would benefit from a rebuild. When it's dropped to 80% it really needs rebuilt! Using the table below will help you determine monitor the condition of your top end.

	Engine is Fresh Measured Value	Engine Down on Power Measured Value * 0.9	Engine NEEDS Rebuilt Measured Value * 0.8
Example	110 psi	110 psi * 0.9 = 99 psi	110 psi * 0.8 = 88 psi
Your Values			

Procedure for Compression Testing

1. Shut off the fuel petcock.
2. Install the compression gauge into the spark plug hole.
3. Hold the throttle to wide open, and kick repeatedly (approximately 20 times) or until the gauge reading does not increase in value with each kick.

Base Gasket Selection

Tools required

- 17mm wrench
- 1mm flexible solder material
- measurement calipers

When rebuilding the 'top end' of your Cobra motorcycle, care must be taken to ensure the proper squish clearance. Squish clearance is defined as the minimum distance between cylinder head and piston at TDC, and there are negative effects of either having too much or too little clearance. Since parts like the crank, connecting rod, cylinder head, piston, and crankcases all have varying tolerances, Cobra offers several different base gasket thicknesses to ensure that you can always set the squish clearance of your engine to factory specifications.

For base gasket replacement use the code (see figure 21 for location) along with the table on the following page reorder the correct thickness gasket.

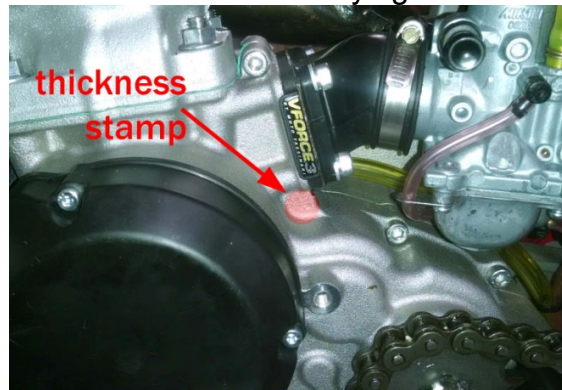

Figure 21

Supplied Base Gasket Thickness		Cobra #
mm	inch	
0.2	0.010	ZCC62402
0.3	0.0125	ZCC62403
0.4	0.015	ZCC62404
0.5	0.020	ZCC62405
0.6	0.025	ZCC62406
0.8	0.031	ZCC62408

NOTE: Tolerances will affect the actual gasket thicknesses.

If during the course of the maintenance more parts than the base gasket is changed, the squish clearance should be measured, and possibly a different base gasket will be required.

The easiest way to measure squish clearance is with 1mm to 1.5mm thick flexible solder wire (available through most popular electronic stores). The process is as follows:

- Assemble the top end of the engine with either; 1) the crankcase stamp recommended base gasket or, 2) if assembling with a new set of cases assemble with a 0.4mm (0.015") base gasket, and torque the head nuts to the proper torque specifications leaving off the spark plug and ignition cover (piston rings can be left off to ease assembly).
- Carefully insert the solder wire through the spark plug hole, into the cylinder far enough such that the tip of the wire touches the left or right side cylinder wall (not the front or back as the piston will rock more and give incorrect measurement).
- Hold the wire at this position and rotate the crankshaft, by the flywheel nut (or kick lever) three revolutions to 'smush' the solder wire.

CAUTION:

If you rotate the flywheel nut in a counterclockwise direction, there is a risk of loosening the nut.

- Pull out the wire and measure the solder thickness at the thinnest location near its tip accurately with the thin tips of calipers.
- Adjust base gasket thickness as necessary to get the desired value.

Upon completion, your final assembly squish clearance should agree with the chart below

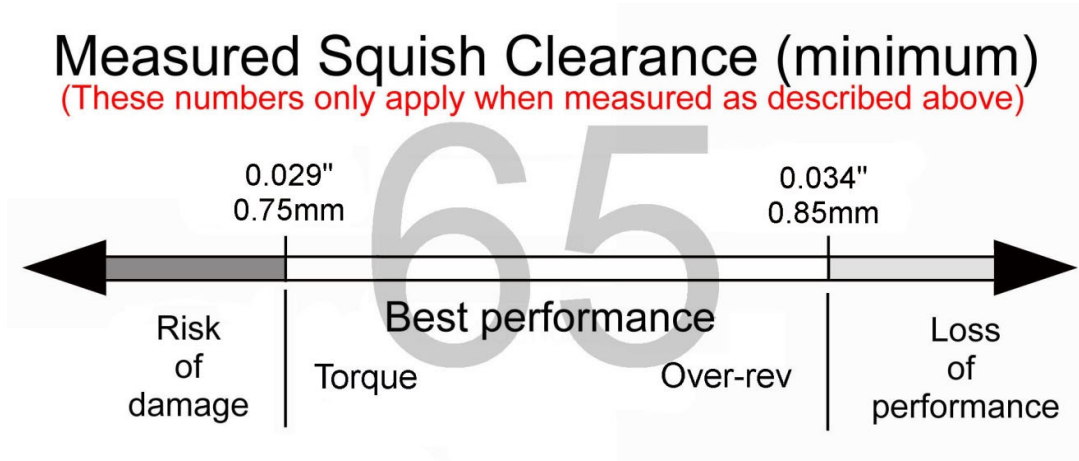

Power Valve

Operation Verification

To verify that the valve operating correctly perform the following steps

1. On the stand, rev the bike above 8600 RPM. The red light on the PVI should illuminate.
2. If not, the most likely scenario is that the PVI is not getting voltage
 - a. Most likely culprit would be the stator

- b. Next likely would be the CDI unit
- 3. If the light comes on then put your finger at the end of the PV solenoid and feel if the plunger 'pops out' above 8600 RPM.
 - a. If not, the most likely scenario is that a wire is broken on the solenoid – to get through the race thread on the Valve Holding Tool (ECC60210) with the valve in the open position.
 - b. If it still does not rev out, it may be that the valve or pin has broken and the plunger is moving but the valve are not. One must remove the assembly from the cylinder to inspect at this point.

Disassemble to remove cylinder

Disassembly

- 4. Disconnect the electrical connector.
- 5. Disconnect the vent hose.
- 6. Remove front fender (optional)
- 7. Remove solenoid clamp and retaining spring
- 8. Loosen hose clamp on solenoids rubber boot
- 9. Remove solenoid assembly through frame
- 10. Remove the two socket head cap screws holding the PV cover to the engine.
- 11. Rotate the cover assembly upward and then slide it upward.
- 12. Remove the return spring.
- 13. Remove the valve and plunger assembly

Clean inspect and assembly

- 1. Clean the components with mineral spirits.
- 2. The inside of the solenoid can also be cleaned with mineral spirits.
- 3. Inspect
 - a. The link for cracks.
 - b. excessive slop in the link joints
 - c. The valve for cracks.
 - d. The boot for cracks.
 - e. O-ring for signs of compromise
 - f. The electrical cable for exposed wires or breaks in the protective covering.

Installation

Power Valve Assembly with the Tool **Cobra has a Power Valve Assembly Tool (ECC60210) to aid assembly of the Power Valve mechanism in the chassis.**

Assemble mechanism out of cylinder and screw on assembly nut 3 – 5 rotations.

Make sure springs go into their pockets and ensure the end of the spring is slid completely to shoulder (see picture to the bottom right)

Do not tighten the assembly nut or it will not be possible to flex the assembly enough to install



1. Apply some premix oil to the outside of the valve and install in the cylinder.

Slide the assembly into the cylinder with the assembly knob installed

CAUTION: If the nut is tightened and left on for riding, the PV will remain in the open position

Assembly nut
ECC60210

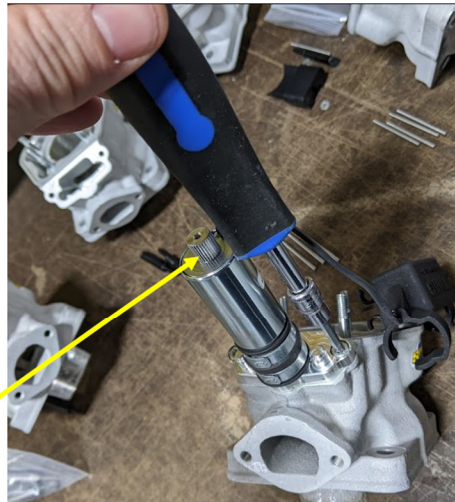

Power Valve Assembly Nut



2. Install the cover with the two screws.
3. Install the vent hose.

Solenoid Troubleshooting:

- 20-21 ohm resistance to be measured across solenoid leads (ohm meter)
- Greater than 18 volts above ~8600 RPM will operate the valve (make red light come on). Diagnostic tool (MCMUTL19) with volt meter.
 1. If insufficient Voltage, replace the stator, or maybe the CDI

Fuel & Air System

Carburetor:

Tools recommended for carburetor service:

- Small flat head screwdriver
- WD-40
- 6mm socket

Your Cobra is equipped with an adjustable carburetor. Some fine-tuning may be needed according to weather condition and altitude. Proper jetting is **very** important for engine performance and engine life. Serious damage to the engine can occur if not properly adjusted.

IDLE ADJUSTMENT:

On each side of the carburetor, there are two adjustment screws. The right side screw with the knurled head is the idle adjustment screw. To raise the idle, turn the screw in clockwise (in 1/4 turn increments) and rev the engine after each adjustment. To lower the idle, turn the screw counter-clockwise.

TOP END JETTING:

Indications that the engine is running too rich (too much fuel for the air) are:

- Engine not revving out or blubbering at high RPMs.
- Engine will not 'clean out'
- Wet or black spark plug

NOTE: Before changing jetting be sure that the air filter is properly cleaned and has the usual amount of air filter oil. An overly dirty air filter can cause the engine to run rich.

If the engine is running rich on the top end it should be leaned out. Leaning it out can be done by:

1. Changing the main jet to a smaller number.
2. Raising the needle clip (this lowers the jet needle) one notch at a time on the slide.

Indications that the engine is running too lean are:

- Engine cutting out on top end.
- Engine overheating and ultimately seizure.
- White spark plug

CAUTION:

It is much safer to operate the engine slightly rich as opposed to slightly lean. This

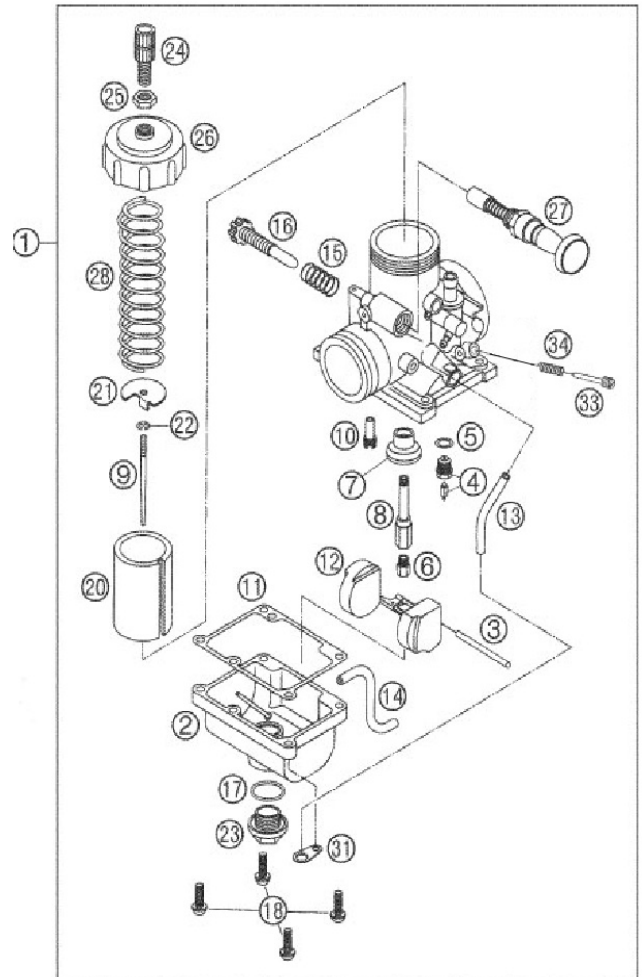

is because an overly rich engine will just run poorly while an overly lean engine will seize, potentially causing an expensive top end rebuild and a DNF.

To richen the carburetor:

1. Change the main jet one number at a time (larger).
2. Lower the needle clip (raising the jet needle) one notch at a time until the engine starts to blubber on the top end, then move the clip back up one notch or until you get the blubber out.

FUEL MIXTURE SCREW

The left side brass screw is a fuel mixture (air) screw. This screw will also richen and lean your engine more on the bottom and mid-range. In warmer conditions, turn the screw out. In colder conditions, turn the screw in. Be sure to keep the carburetor very clean and make sure you don't have water or dirt in the carburetor bowl. Use automotive carburetor cleaner or WD-40 to clean the carburetor inside and out. Turning the screw in richens the mixture at partial throttle openings. Turning the screw out, leans it.

Cleaning the carburetor:

WARNING

Clean the carburetor in a well-ventilated area, and take care that there is no spark or flame anywhere near the working area; this includes any appliance with a pilot light. Because of the danger of highly flammable liquids, do not use gasoline or low flash-point solvent to clean the carburetor.

1. Make sure the fuel is shut off.
2. Remove the carburetor.
3. Drain the fuel from the carburetor.
4. Disassemble the carburetor.
5. Immerse all the metal parts in a carburetor cleaning solution.
6. After the parts are cleaned, dry them with compressed air.
7. Blow out the fuel passages with compressed air.
8. Assemble the carburetor
9. Install the carburetor onto the motorcycle.

Rear Shock

The rear shock is fully serviceable but it is recommended that only trained professionals should service your shock. Contact Cobra or another qualified specialist for questions and service of your CX65 shock.

Brakes

Proper Brake adjustment must have a slight amount of freeplay from the pedal/lever to the master cylinder piston. Without freeplay, it is difficult to ensure that piston is not blocking the hydraulic return path which allows fluid to return to the master cylinder upon release of the pedal/lever. If the system does not allow

sufficient return flow, the brake system will lock up during operation as the master cylinder pumps fluid to the caliper that is unable to return to the master cylinder as the lever is released.

Rear Brakes

Rear brake bleeding is a 5-step process.

1. Remove the reservoir cap on the master cylinder and top of with DOT 4 or 5.1 fluid. During all these steps, make sure you monitor the fluid level and 'top off' when necessary.
2. Adjust the brake plunger for free play. There must be at least some free play between the adjustable plunger and the master cylinder piston. Push the pedal up and down to feel for free play and adjust if necessary. It may be helpful to remove the rubber boot. Improper adjustment will not allow fluid from the caliper to return to the master cylinder up release of the brake pedal.
3. Pressure bleed the system. Push down once on the brake pedal, solidly and completely, and open and close the caliper bleed, before releasing the pedal. Repeat this step at least 5 times looking for bubbles. Typically, bubbles are seen on the 4th or 5th attempt. If bubbles are seen repeat until no bubbles appear.
4. Minimize the caliper volume. Using channel locking pliers, or similar, squeeze the caliper as shown to push the piston back as far as possible into the caliper. While squeezing, open and close the caliper bleeder looking for bubbles. Repeat at least three times looking for bubbles. If bubbles are seen repeat until not bubbles appear.
5. Overfill the master cylinder to minimize the amount of air in the reservoir before reinstalling the cap. Yes, you will lose some fluid when the cap goes on. Have the rubber in the cap pushed up to minimize its volume.

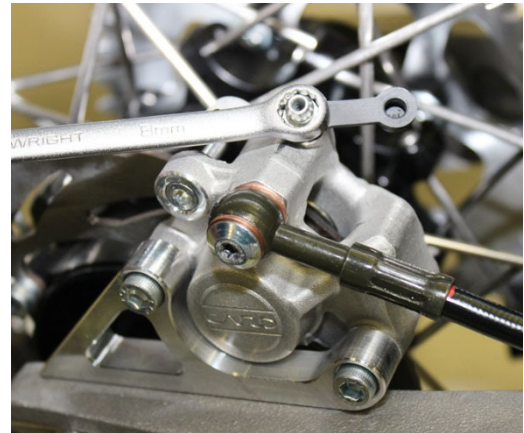

Front Brakes

Bleeding of the front brakes is similar but step 4 requires the use of a screwdriver to force the pads & pistons back into the caliper.

See the maintenance section at the beginning of this manual for proper brake lever adjustment.

If the adjustment is set properly and the brakes have been properly bled and the system is still not responsive enough, perform the steps below to 'exercise' the pistons and seals.

1. Remove the caliper from the mount.
2. Remove the brake pads from the caliper (remove the clip before removing the bolt).
3. Pump the front brake lever to make the pistons move toward the center of the caliper.
 - a. Likely if the bike has much time, the pistons just move back and forth and do not pump out as they should.
 - b. Our goal here is to free each piston up so that they will pump out
4. Keep pumping the lever until one piston travels ~ 1/8" (3mm) out.
5. Push it back in & repeat several times.
6. Once you have one piston moving freely, clamp, block, or hold it in place so that it forces other pistons to work.
7. After you have all 4 pistons moving easily, reinstall the brake pads and spring.
8. Before installing the caliper back onto the fork leg and wheel, pump the brakes so that the pads will need spread slightly to install over the rotor.
9. Spread the pads just enough so that the caliper will fit over the rotor (If you spread them too far they may not pump up properly).

Front Wheel

Assembly

- Put the wheel in place and install the axle and caps. Torque the caps to 45 Nm (33 ft-lb)
- Place the bike on the ground and 'exercise' the suspension a couple times while applying the front brakes.
- Tighten the four axle pinch bolts to 12 Nm (106 in-lb)

Ignition

To verify if the charging coils for the ignition are good use an ohm meter and two fine point leads (paper clips will work) and measure the resistance across the blue and white wires in the six pin stator connector. The resistance value should be $5 \Omega \pm .3 \Omega$.

To verify the coil with an ohm meter.

1. Test for resistance from the metal in the cap to the coil frame. It should be $\sim 10 \text{ k}\Omega$. If not, there may be a broken wire.
2. Test from either of the leads to the connector to the frame ground. It should be infinite. If not, a wire may have shorted to ground.
3. Test the resistance across both leads in the connector should be near 0Ω . If not, there may be a short or broken wire.

Tuning

Gearing

Front Sprocket				Rear Sprocket	Gear Ratio
		14		38	2.71
			15	41	2.73
		14		39	2.79
			15	42	2.80
	13			37	2.85
		14		40	2.86
			15	43	2.87
	13			38	2.92
		14		41	2.93
			15	44	2.93
	13			39	3.00
		14		42	3.00
			15	45	3.00
			15	46	3.07
		14		43	3.07
	13			40	3.08
12				37	3.08
			15	47	3.13
		14		44	3.14
	13			41	3.15
12				38	3.17
			15	48	3.20
		14		45	3.21
	13			42	3.23
12				39	3.25
			15	49	3.27
		14		46	3.29
	13			43	3.31
12				40	3.33
			15	50	3.33
		14		47	3.36
	13			44	3.38
			15	51	3.40
12				41	3.42

Suspension

Adjustment:

1. Front forks
 - 1.1. Fork oil
 - 1.1.1. Oil type
 - 1.1.1.1. Heavier weight oil – more damping – slower responding
 - 1.1.1.2. Lighter weight oil – less damping – quicker responding
 - 1.1.2. Oil quantity / level
 - 1.1.2.1. Greater quantity / higher level – greater bottoming resistance, stiffer near the end of the travel.
 - 1.1.2.2. Smaller quantity / lower level – less bottoming resistance, less stiff near the end of the travel.
 - 1.2. Fork spring
 - 1.2.1. Stiffer spring (higher spring rate) – stiffer throughout the travel.
 - 1.2.2. Less stiff spring (lower spring rate) – less stiff throughout the travel.
 - 1.3. Gas pressure – always bleed off any pressure.
 - 1.4. Fork height
 - 1.4.1. Rise in clamps for quicker turning.
 - 1.4.2. Lower in clamps for improved straight line stability.
2. Rear shock
 - 2.1. Preload adjustment
 - 2.1.1. More preload (greater distance) – less race sag.
 - 2.1.2. Less preload (smaller distance) – more race sag.
 - 2.2. Shock spring
 - 2.2.1. Stiffer spring – stiffer throughout the travel.
 - 2.2.2. Less stiff spring – less stiff throughout the travel.
 - 2.3. Compression damping
 - 2.3.1. Harder (more damping, slower) – adds resistance to the suspension motion when the suspension is compressing.
 - 2.3.2. Softer (less damping, quicker) – reduces resistance to the suspension motion when the suspension is compressing.
 - 2.4. Rebound damping
 - 2.4.1. Harder (more damping, slower) – adds resistance to the suspension motion when the suspension is returning to full length.
 - 2.4.2. Softer (less damping, quicker) - reduces resistance to the suspension motion when the suspension is returning to full length

Front Fork Operation

The front suspension on the CX65 works under the principals of hydraulic damping, and it features full adjustability to help tune the fork to meet each rider's needs. The CARD fork contains MXT 'Smart Leg' technology that provides very progressive operation; allowing a small bike to perform well on track surfaces ripped up by larger machines.

The key to Smart Leg technology is to understand that each leg has a different role. The brake side leg features a conventional open cartridge. This cartridge

handles both standard compression and rebound damping duties. Rebound damping is adjustable on the fork cap, and compression damping is adjusted at the bottom of the fork. The other leg (the Smart Leg) has no rebound damping, and it contains both a speed sensitive compression damping mechanism as well as a position sensitive one. This design allows for a firm low speed response, controlling rapid chassis pitch, which promotes stability and control. The fork produces significantly less mid and high-speed compression until it travels into the progressive / speed sensitive portion of the smart leg. The speed sensitive compression component is adjustable at the top of the fork.

The combination of the Smart Leg and the conventional leg allows the fork to be very supple throughout all low amplitude operation and yet take punishing hits; producing a progressively increasing damping rate that slows the forks movement as it approaches full bottom. Therefore, the Smart Leg also acts as a hydraulic bottoming control device. Finally, the large degree of adjustability in both legs allows the fork to be tuned to meet each rider's size, ability, and type of riding they do (motocross, off-road, flat track, etc).

Fork Damping Adjustments

Tools required

- Small flat blade screwdriver



REBOUND ADJUSTMENT

At the base of the conventional leg is adjustment screw that controls the compression damping. Turning this clockwise increases damping and counter-clockwise will decrease it. illustrated by the "HARD" and the figure at the right.

The speed at which the fork rebounds can be adjusted at the top of the conventional leg. Turning the adjustment screw clockwise slows the rate at which the fork extends after being compressed, and likewise, turning the screw counter-clockwise returns the leg to its extended position faster. As shown in the figure, 'S' (slower) and 'F' (faster) are etched into the cap as an adjustment guide.

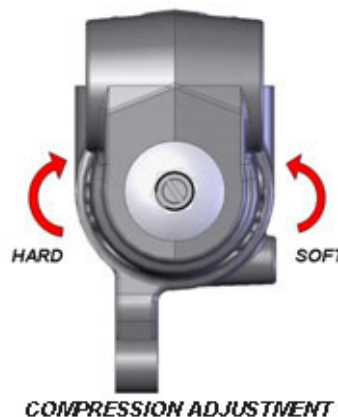

another amount of screw turning it This is "SOFT" in



The Smart Leg cap is labeled “Speed Sensitive Bottoming Control”, and this adjuster provides a range of control over how progressive the fork feels. Turning the screw clockwise increases the fork’s resistance to bottoming, while turning the screw counter-clockwise decreases it. On the track, this effect will be felt on sections where the fork is forced to move very quickly such as on harsh landings or when traversing sharp edged bumps.

Rear Shock Adjustments

Always start with standard settings and make damping changes in no more than two click increments and only make one change at a time.

Symptom	Action
Rear end feels stiff on small bumps	Softer Low Speed Compression Damping
Rear end ‘sways’ on straights	Harder Low Speed Compression Damping
Bike tends to jump ‘rear end high’	Harder High Speed Compression
Bike tends to jump ‘rear end low’	Softer High Speed Compression
Frequent rear end bottoming	Harder Compression Damping
Bottoms after end of continuous bumps	Softer rebound damping
Rear end ‘kicks’ over square edge bumps	1) Harder rebound, 2) Softer Low and High Speed Compression
Rear end feels stiff under acceleration bumps.	Softer Rebound and/or Stiffer Low Speed Compression Damping

Proactive Suspension Adjustments

Once you have the suspension adjusted for decent overall feel, you can make proactive adjustments when faced with different racing conditions.

Situation	Actions
Sand track	Lower the rear end (increase race sag).
Sand track	Stiffer compression and rebound damping.
Long fast track	Lower the forks in the clamps by 3 mm.
Tight slow track	Raise the forks in the clamps by 3 mm.
Mud track	Lower the bike if the rider has difficulties touching the ground.

Shock preload

Loosen the set screw and turn the spring perch in full turn increments to get the desired sag settings.

NOTE: Always leave the spring perch rotated in such position so that the set screw is easily accessible.

Shock Damping

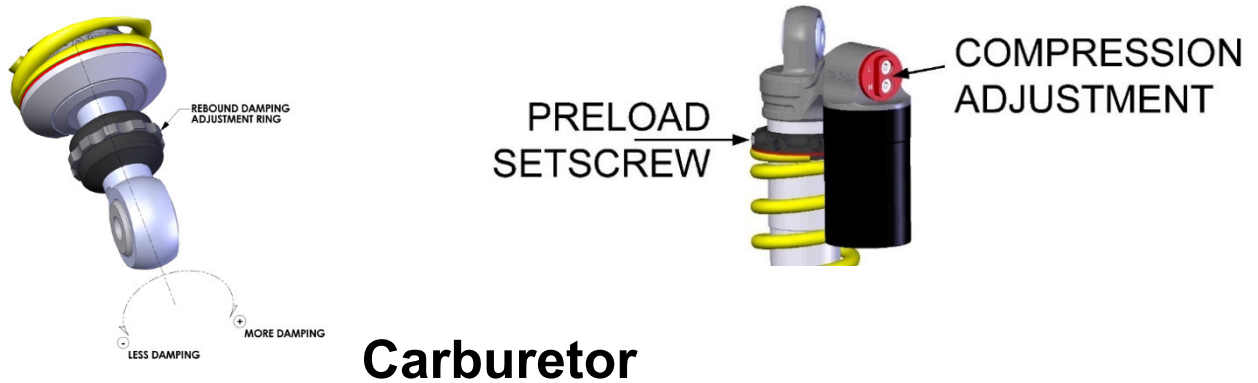

Carburetor

Although your Cobra is sent from the factory with the carburetor jetted for optimal performance, you may find it necessary to adjustment your particular jetting due to current weather conditions, altitude, fuel variations, and/or engine modifications.

CAUTION:

Proper jetting is very important for engine performance and engine life. Symptoms of improper jetting are listed below.

- Symptoms of incorrect oil or oil / fuel ratio
 - Poor acceleration
 - Misfire at low engine speeds
 - Excessive smoke
 - Spark plug fouling
 - Excessive black oil dripping from exhaust system
- Symptoms of too rich a fuel mixture
 - Poor acceleration
 - Engine will not 'rev' out, blubbers on top
 - Misfire at low engine speeds
 - Excessive smoke
 - Spark plug fouling
 - Wet, black, or overly dark spark plug (when removed for inspection)
- Symptoms of too lean a fuel mixture
 - Pinging or rattling
 - Erratic acceleration
 - Same actions as running out of fuel
 - High engine temperature
 - White spark plug (when removed for inspection)

NOTE: When inspecting the spark plug to evaluate jetting, a properly jetted machine will produce a spark plug that is dry and light tan in color.

Environmental and altitude related mixture adjustments		
Condition	Mixture will be	Required adjustment
Cold air	Leaner	Richer
Warm air	Richer	Leaner
Dry air	Leaner	Richer
Very humid air	Richer	Leaner
Low altitude	Standard	None
High altitude	Richer	Leaner
Low barometric pressure	Richer	Leaner
High barometric pressure	Leaner	Richer

NOTE: Before making any carburetor jetting changes verify that:

- You are using the proper fuel and oil
- The fuel is fresh and uncontaminated
- The oil and fuel have been mixed in the proper ratio
- The carburetor is clean (no plugged jets)
- The air filter is properly clean and oiled
- The float height is within proper specification (proper measuring technique is described later in this section)

NOTE: Perform all jetting changes on a motorcycle that has been warmed up to proper operating temperature.

The carburetor on your Cobra motorcycle is quite adjustable. Figure 49 shows its range of adjustment and in particular what adjustable component affects what range of operation (specifically throttle position).

FUEL SCREW ADJUSTMENT: Adjust for throttle response

The air adjustment screw is located on the left side of the carburetor. It requires the use of a small flat blade screw driver for adjustment. After adjusting for proper throttle response, use the idle screw to adjust the desired idle speed.

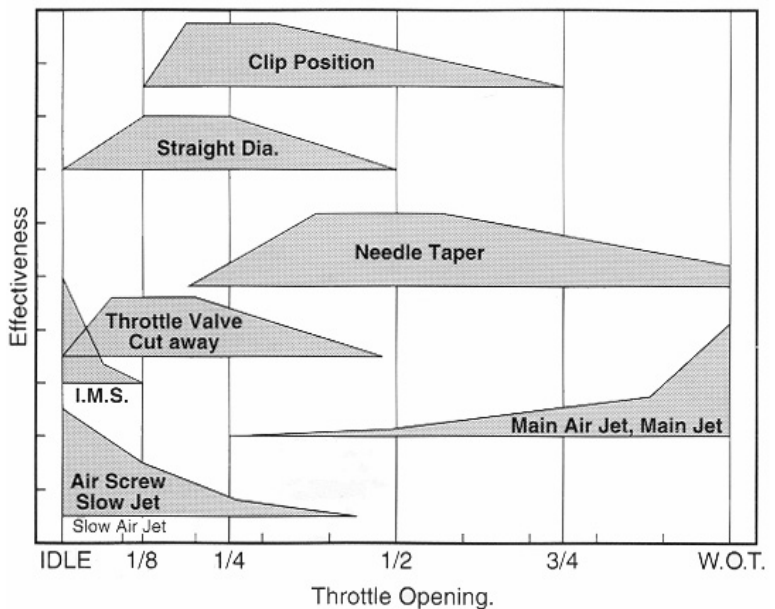

NOTE: If the air screw requires more than 3 turns out, replace the pilot jet for one that is one size leaner (smaller number) then readjust the fuel screw.

IDLE ADJUSTMENT:

Adjust for desired idle speed

The idle speed screw is located on the right side of the carburetor. It is hidden behind the exhaust stinger pipe and is barely reachable with a screwdriver. To raise the idle, turn the screw in, clockwise, (in 1/4 turn increments) and rev the engine after each adjustment. To lower the idle, turn the screw counter-clockwise.

TOP END JETTING:**Adjust for clean full throttle acceleration**

Jet your top end (main jet) based on the acceleration of your Cobra Motorcycle on the longest straight at the track. Observe any of the lean or rich symptoms (spark plug appearance and bike performance) listed above and change your jetting accordingly.

PART THROTTLE**Adjust for desired acceleration**

Using an area of the track that allows the rider to operate at mid throttle, transition (accelerate, or 'roll on') from closed, or mostly closed throttle, to a larger throttle opening. Observe the rich and lean symptoms listed above. Adjust the jet needle position by moving the clip from its current position (move the clip higher on the needle to make the bike run leaner, or move the clip lower on the needle to make the bike run richer) to one higher or lower.

Troubleshooting

1) Engine operates erratically

- a) Faulty stator
- b) An air leak
 - i) Base gasket
 - ii) Intake / reed gaskets
 - iii) Crank seals
 - iv) Crank case gasket

2) Engine is down on power

- a) Jetting is incorrect
- b) Silencer needs repacked
- c) Exhaust pipe
 - i) Has excess carbon buildup
 - ii) Has large dent in it
- d) Compression is low
 - i) Piston
 - ii) Rings
- e) Reeds are damaged
- f) Ignition timing is incorrect
- g) Stator needs replaced

3) Engine is excessively loud

- a) Silencer needs repacking

4) Engine 'blubbers' at high RPMs

- a) Jetting too rich
- b) Stator needs replaced

5) Engine won't start

- a) Fuel
 - i) None in tank
 - ii) Is sour or bad
- b) Carburetor is dirty
- c) Ignition
 - i) Spark plug fouled
 - ii) Spark plug cap off
 - iii) Engine Shut-off 'kill' switch is shorted
 - iv) Bad electrical ground
 - v) Stator winding damaged
- d) Exhaust is plugged with object or flooded fuel
- e) Engine is flooded
- f) Cracked, broken, or jammed reed pedal
- g) Excessive piston or cylinder wear
- h) Clutch bolt or shoe dragging on basket (drum).

6) Engine won't idle

- a) Idle knob needs adjusted
- b) Carburetor jets are dirty
- c) Choke is stuck on
- d) Air leak

7) Engine won't rev out on top end

- a) Jetting too rich
- b) Ignition issues
- c) PV not opening – if this is suspected to be the case please check Verifying PV operation in the Service section of this manual.

Change Control

Who	Rev	Date Pub	Assy/pg	Changes made
PDM	1	NOT YET	SWINGARM	CHANGED CHAIN GUIDE MOUNTING HARDWARE FROM 40MM FLANGE HEAD AND NUT TO 45MM SHCS AND NYLOCK FLANGE NUT
PDM	1	8/26/24	Top end	Added top EKC62401 top end kits
PDM	2	9/10/24	PLASTIC	BLK AND WHT FOR BODY WORK KITS WERE SWAPPED, corrected part number for FXX kit
pdm	3	Not yet	Rear brake	Master cylinder # corrected to BKMU0014
PDM	3	Not yet	Shock - internal	Replaced SKC60002 with SKMU0003 rebuild kit
PDM	3	10/22/24	Bars	Throttle to FCMU0043 and bar clamp to TCMU0060BLK
PDM	4	NOT YET	EXHAUST	XCKG0009 was replaced by XCC60020
PDM	4		Shock page	Top bolt HCBF1039, bottom bolt HCSP1055
PDM	4	11/12/34	intake	Intake boot to ECC60240
PDM	5		Front & rear wheels	Removed WCDC0008 rim lock spacer
PDM	5		Cooling sys	Added drain bolt and gasket
PDM	5	1/15/25	Clutch cap	Changed description